



---

## TEATRO TITO MARRONE ERICE

**Project Quotation** **1**

---

**Index** **2**

---

**Project Note** **5**

---

**Project Equipment list** **6**

---

**Project Compliance** **8**

---

**Sistema 1** **11**

---

Sistema 1 Equipment List 11

---

Sistema 1 Details 13

---

Sistema 1 Seasonal Power Consumption 14

---

Sistema 1 Graph 15

---

Sistema 1 Schematic overview 17

---

Sistema 1 <whole system> FloorPerspective3D 20

---

Sistema 1 Outdoor Unit Details 21

---

Sistema 1 Wiring Diagram 22

---

Sistema 1 Piping & Wiring Diagram 25

---

Sistema 1 Control Wiring Diagram 28

---

Sistema 1 Power Wiring Diagram 31

---

Sistema 1 SEER/SCOP 34

---

Sistema 1 Part Load Table 35

---

**Sistema 2** **36**

---

Sistema 2 Equipment List 36

---

Sistema 2 Details 38

---

Sistema 2 Seasonal Power Consumption 39

---

Sistema 2 Graph 40

---

Sistema 2 Schematic overview 42

---

Sistema 2 <whole system> FloorPerspective3D 43

---

---

## TEATRO TITO MARRONE ERICE

Sistema 2 Outdoor Unit Details	44
Sistema 2 Dx kit Details	45
Sistema 2 Wiring Diagram	46
Sistema 2 Piping & Wiring Diagram	47
Sistema 2 Control Wiring Diagram	48
Sistema 2 Power Wiring Diagram	49
Sistema 2 Part Load Table	50
<b>Sistema 3</b>	<b>51</b>
Sistema 3 Equipment List	51
Sistema 3 Details	52
Sistema 3 Seasonal Power Consumption	54
Sistema 3 Graph	55
Sistema 3 Schematic overview	57
Sistema 3 <whole system> FloorPerspective3D	61
Sistema 3 Outdoor Unit Details	62
Sistema 3 Wiring Diagram	63
Sistema 3 Piping & Wiring Diagram	67
Sistema 3 Control Wiring Diagram	71
Sistema 3 Power Wiring Diagram	75
Sistema 3 SEER/SCOP	79
Sistema 3 Part Load Table	80
<b>Project Wiring Diagram</b>	<b>81</b>
Project Wiring Diagram	81
Control System	89
<b>Total Equipment List</b>	<b>90</b>
<b>Outdoor Unit List</b>	<b>91</b>

---

## TEATRO TITO MARRONE ERICE

<b>Indoor Unit List</b>	<b>92</b>
<hr/>	
<b>Sistema 1</b>	<b>93</b>
<hr/>	
Sistema 1 Piping Diagram	93
<hr/>	
Sistema 1 Wiring Diagram	94
<hr/>	
Sistema 1 System Diagram	95
<hr/>	
<b>Sistema 2</b>	<b>96</b>
<hr/>	
Sistema 2 Piping Diagram	96
<hr/>	
Sistema 2 Wiring Diagram	97
<hr/>	
Sistema 2 System Diagram	98
<hr/>	
<b>Sistema 3</b>	<b>99</b>
<hr/>	
Sistema 3 Piping Diagram	99
<hr/>	
Sistema 3 Wiring Diagram	101
<hr/>	
Sistema 3 System Diagram	103
<hr/>	

**Project:** TEATRO TITO MARRONE ERICE

**Notes:** Equivalent length is calculated by coefficients:  
1,0:Sistema 1, Sistema 3, 1,2:Sistema 2  
The user is responsible for ensuring that all data entered is correct.  
Equipment selections have been based on the Design Guidelines stated within the Toshiba SMMS-e/SHRM-e/SMMS-7/MiNi-SMMS7/MiNi-SMMS-e/Side Blow VRF/MiNi-SMMS Installation Manual.  
It is the responsibility of the consultant or contractor, to verify and confirm that the equipment selection and system design is correct before installation.  
Please note that in the event of future system expansion being allowed for in the system design or a change in cooling/heating requirements, a re-evaluation of the air conditioning system must be made prior to final installation.  
Sistema 1, REGIA exceeds the allowed maximum of 0,390 kg/m<sup>3</sup>.  
Sistema 3, CAM 1 SN P3, CAM 2 SN P3, CAM 3 SN P3, CAM 1 SN P2, CAM 2 SN P2, CAM 3 SN P2, CAM 1 SN P1, CAM 2 SN P1, CAM 3 SN P1, CAM 1 DX P3, CAM 2 DX P3, CAM 3 DX P3, CAM 1 DX P2, CAM 2 DX P2, CAM 3 DX P2, CAM 1 DX P1, CAM 2 DX P1, CAM 3 DX P1 exceeds the allowed maximum of 0,390  
To comply with EN 378:2016 some form of additional protection must be used.

<b>Sistema 1:</b>	IMPIANTO DI CLIMATIZZAZIONE SALA TEATRO
<b>Sistema 2:</b>	IMPIANTO DI TRATTAMENTO ARIA E CLIMATIZZAZIONE SALA TEATRO
<b>Sistema 3:</b>	IMPIANTO DI CLIMATIZZAZIONE CAMERINI

# Project Equipment List

## TEATRO TITO MARRONE ERICE

### Outdoor Units

Model	Quantity	Description
MMY-SAP1206HT8P-E	1	Super Modular Multi System (SMMS-e)
MMY-MAP1606HT8JP-E	2	Super Modular Multi System (SMMS-e)
MMY-MAP2006HT8P-E	1	Super Modular Multi System (SMMS-e)
MMY-MAP2206HT8JP-E	1	Super Modular Multi System (SMMS-e)
MMY-MAP2206HT8P-E	1	Super Modular Multi System (SMMS-e)

### Indoor Units

Model	Quantity	Description
MMK-AP0057HP-E	18	0,6HP High Wall Compact
MMK-AP0093HP1-E1	1	1,0HP High Wall Standard
MMF-AP0566H-E	10	6,0HP Tall Floor Standing

### DX Kit Item

Model	Quantity	Description
MM-DXC010	1	DX Controller
MM-DXC012	4	DX Controller
MM-DXV280	5	DX Valve Kit

### Y Joints

Model	Quantity	Description
RBM-BT24E	3	Outdoor Unit Branch Kit
RBM-BY305E	10	Y-Joint
RBM-BY105E	4	Y-Joint
RBM-BY205E	2	Y-Joint
RBM-BY55E	15	Y-Joint

### Accessories

Model	Quantity	Description
BMS-IFMB0TLR-E	11	MB Interface
RBC-AS21E2	1	Wired remote controller
RBM-PMV0363E	1	PMV Kit

### Central Control Devices

Model	Quantity	Description
BMS-CT2560U-E	1	Touch Screen
BMS-SM1280HTLE	1	Smart Manager

### Piping Length

Pipe Diameter	Total Length	Gas Side	Discharge Side	Liquid Side
6,4mm	33,00 m	0,00 m	0,00 m	33,00 m
9,5mm	113,50 m	33,00 m	0,00 m	80,50 m
12,7mm	92,50 m	50,00 m	0,00 m	42,50 m
15,9mm	44,50 m	30,50 m	0,00 m	14,00 m
19,1mm	36,00 m	4,00 m	0,00 m	32,00 m
22,2mm	97,50 m	23,50 m	0,00 m	74,00 m
28,6mm	32,00 m	32,00 m	0,00 m	0,00 m

# Project Equipment List

## Piping Length

Pipe Diameter	Total Length	Gas Side	Discharge Side	Liquid Side
34,9mm	19,00 m	19,00 m	0,00 m	0,00 m
41,3mm	84,00 m	84,00 m	0,00 m	0,00 m

## Total Refrigerant Charge Amount

Refrigerant (R410A)	Amount	Description
Outdoor Unit	34,500 kg	Refrigerant amount charged in factory
Additional Refrigerant	63,680 kg	Amount needed for the pipes at the site
Outdoor Unit	23,000 kg	Refrigerant amount charged in factory
Additional Refrigerant	28,468 kg	Amount needed for the pipes at the site
Outdoor Unit	5,700 kg	Refrigerant amount charged in factory
Additional Refrigerant	11,215 kg	Amount needed for the pipes at the site
<b>TOTAL:</b>	<b>166,563 kg</b>	

## Outdoor Design Temperature

System	Mode	Description	Temperature
Sistema 1	Cooling	Dry Bulb temperature	35,0 °C
	Heating	Wet Bulb temperature	6,0 °C
Sistema 2	Cooling	Dry Bulb temperature	35,0 °C
	Heating	Wet Bulb temperature	6,0 °C
Sistema 3	Cooling	Dry Bulb temperature	35,0 °C
	Heating	Wet Bulb temperature	6,0 °C

# System Equipment List

## Sistema 1

### Outdoor Units

Model	Quantity	Description
MMY-AP5416HT8P-E (J)	1	Super Modular Multi System (SMMS-e)
MMY-MAP1606HT8JP-E		Super Modular Multi System (SMMS-e)
MMY-MAP2206HT8JP-E		Super Modular Multi System (SMMS-e)

### Indoor Units

Model	Quantity	Description
MMK-AP0093HP1-E1	1	1,0HP High Wall Standard
MMF-AP0566H-E	10	6,0HP Tall Floor Standing

### Y Joints

Model	Quantity	Description
RBM-BT24E	2	Outdoor Unit Branch Kit
RBM-BY305E	7	Y-Joint
RBM-BY105E	2	Y-Joint
RBM-BY205E	1	Y-Joint

### Accessories

Model	Quantity	Description
BMS-IFMB0TLR-E	11	MB Interface
RBC-AS21E2	1	Wired remote controller
RBM-PMV0363E	1	PMV Kit

### Piping Length

Pipe Diameter	Total Length	Gas Side	Discharge Side	Liquid Side
6,4mm	3,00 m	0,00 m	0,00 m	3,00 m
9,5mm	20,00 m	3,00 m	0,00 m	17,00 m
12,7mm	8,00 m	0,00 m	0,00 m	8,00 m
15,9mm	27,00 m	17,00 m	0,00 m	10,00 m
19,1mm	18,00 m	0,00 m	0,00 m	18,00 m
22,2mm	80,00 m	8,00 m	0,00 m	72,00 m
28,6mm	11,00 m	11,00 m	0,00 m	0,00 m
34,9mm	17,00 m	17,00 m	0,00 m	0,00 m
41,3mm	72,00 m	72,00 m	0,00 m	0,00 m

### Total Refrigerant Charge Amount

Refrigerant (R410A)	Amount	Description
Outdoor Unit	34,500 kg	Refrigerant amount charged in factory
Additional Refrigerant	63,680 kg	Amount needed for the pipes at the site
<b>TOTAL:</b>	<b>98,180 kg</b>	

### Outdoor Design Temperature

Mode	Description	Temperature
Cooling	Dry Bulb temperature	35,0 °C
Heating	Wet Bulb temperature	6,0 °C

### Electronic Information(OutdoorUnits)

Property	Value	Description
MOCP(A)	160	Maximum Overcurrent Protection
MCA(A)	120,9	Minimum Circuit Amps
Protection Device Size(A)		Follow applicable local standard as needed



# System Equipment List

---

## **Electronic Information(OutdoorUnits)**

Property	Value	Description
Wire(cable size)(mm <sup>2</sup> ) or AWG(#)		Follow applicable local standard as needed

## **Electronic Information(IndoorUnits)**

Property	Value	Description
Total MCA(A)	16,04	
Protection Device Size(A)		Follow applicable local standard as needed
Wire(cable size)(mm <sup>2</sup> ) or AWG(#)		Follow applicable local standard as needed

# System Details

## Sistema 1

### Outdoor Unit

Model Name	Cooling (kW)		Heating (kW)		Diversity	
	Rated	Corrected	Rated	Corrected	System	Building
MMY-AP5416HT8P-E (J)	151,50	120,38	164,00	155,20	113%	0%

### Outdoor Unit Combination

Header	Follower1	Follower2	Follower3	Follower4
MMY-MAP2206HT8JP-E	MMY-MAP1606HT8JP-E	MMY-MAP1606HT8JP-E		

### Indoor Units

Model Name	UnitName &Room	Capacity Code	Fan Speed Air flow (m³/h)	Capacity (Total/Sensible) [kW]			
				Mode	Rated	Corrected	Required
MMF-AP0566H-E	U.I.COL.1 PLATEA	6	MediumPlus	Cooling	16,00/11,40	11,83/7,97	270,00/100,00
				Heating	18,00	15,25	300,00
MMF-AP0566H-E	U.I.COL.10 PLATEA	6	MediumPlus	Cooling	16,00/11,40	11,83/7,97	270,00/100,00
				Heating	18,00	15,25	300,00
MMF-AP0566H-E	U.I.COL.9 PLATEA	6	MediumPlus	Cooling	16,00/11,40	11,83/7,97	270,00/100,00
				Heating	18,00	15,25	300,00
MMF-AP0566H-E	U.I.COL.8 PLATEA	6	MediumPlus	Cooling	16,00/11,40	11,83/7,97	270,00/100,00
				Heating	18,00	15,25	300,00
MMF-AP0566H-E	U.I.COL.7 PLATEA	6	MediumPlus	Cooling	16,00/11,40	11,83/7,97	270,00/100,00
				Heating	18,00	15,25	300,00
MMF-AP0566H-E	U.I.COL.6 PLATEA	6	MediumPlus	Cooling	16,00/11,40	11,83/7,97	270,00/100,00
				Heating	18,00	15,25	300,00
MMF-AP0566H-E	U.I.COL.5 PLATEA	6	MediumPlus	Cooling	16,00/11,40	11,83/7,97	270,00/100,00
				Heating	18,00	15,25	300,00
MMF-AP0566H-E	U.I.COL.4 PLATEA	6	MediumPlus	Cooling	16,00/11,40	11,83/7,97	270,00/100,00
				Heating	18,00	15,25	300,00
MMF-AP0566H-E	U.I.COL.3 PLATEA	6	MediumPlus	Cooling	16,00/11,40	11,83/7,97	270,00/100,00
				Heating	18,00	15,25	300,00
MMF-AP0566H-E	U.I.COL.2 PLATEA	6	MediumPlus	Cooling	16,00/11,40	11,83/7,97	270,00/100,00
				Heating	18,00	15,25	300,00
MMK-AP0093HP1-E1	SALA REGIA	1	High 600	Cooling	2,80/2,10	2,07/1,51	4,00/5,00
				Heating	3,20	2,71	1,00

### Floor Information

Floors	Room Name	Indoor Units		Design Conditions			
		Name	Model	Mode	DB[°C]	WB[°C]	RH[%]
SALA TEATRO	PLATEA	U.I.COL.1	MMF-AP0566H-E	Cooling	27,0	19,6	50,00
		U.I.COL.10	MMF-AP0566H-E	Heating	20,0		
		U.I.COL.9	MMF-AP0566H-E				
		U.I.COL.8	MMF-AP0566H-E				
		U.I.COL.7	MMF-AP0566H-E				
		U.I.COL.6	MMF-AP0566H-E				
		U.I.COL.5	MMF-AP0566H-E				
		U.I.COL.4	MMF-AP0566H-E				
		U.I.COL.3	MMF-AP0566H-E				
		U.I.COL.2	MMF-AP0566H-E				

# Seasonal Power Consumption

System Name Sistema 1

Average Daily Temperature

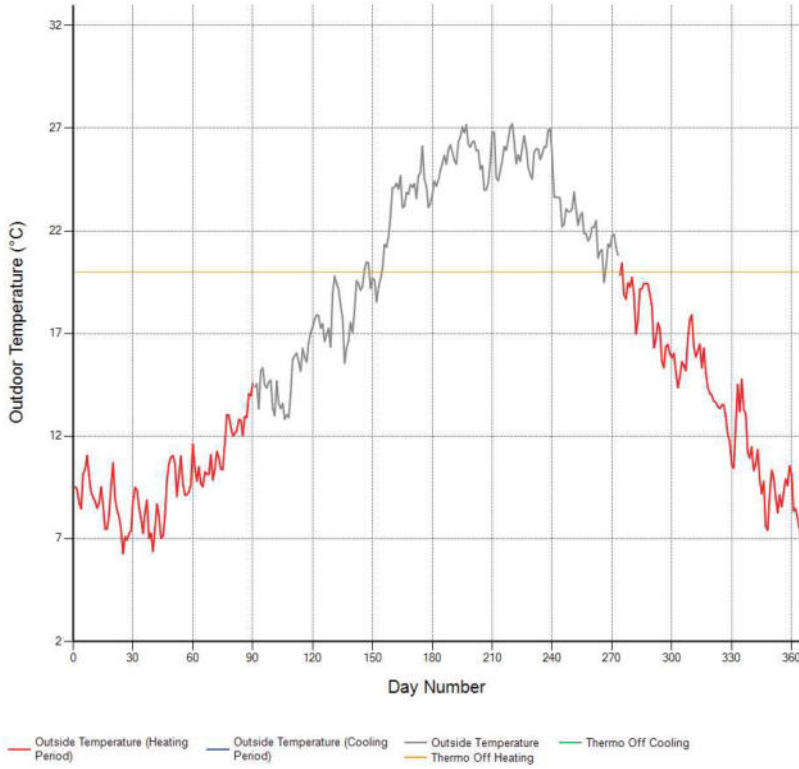

Yearly Outdoor Temperature Condition

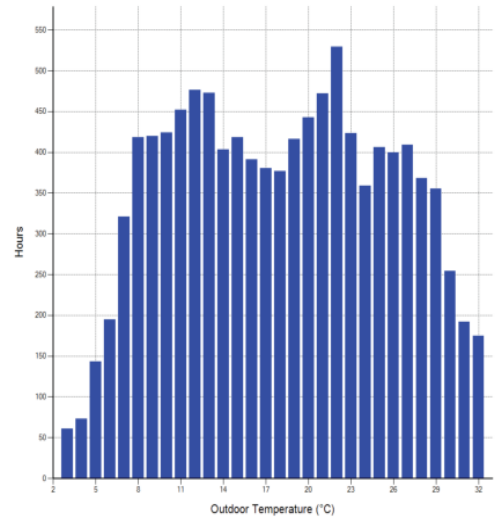

Capacity Trend

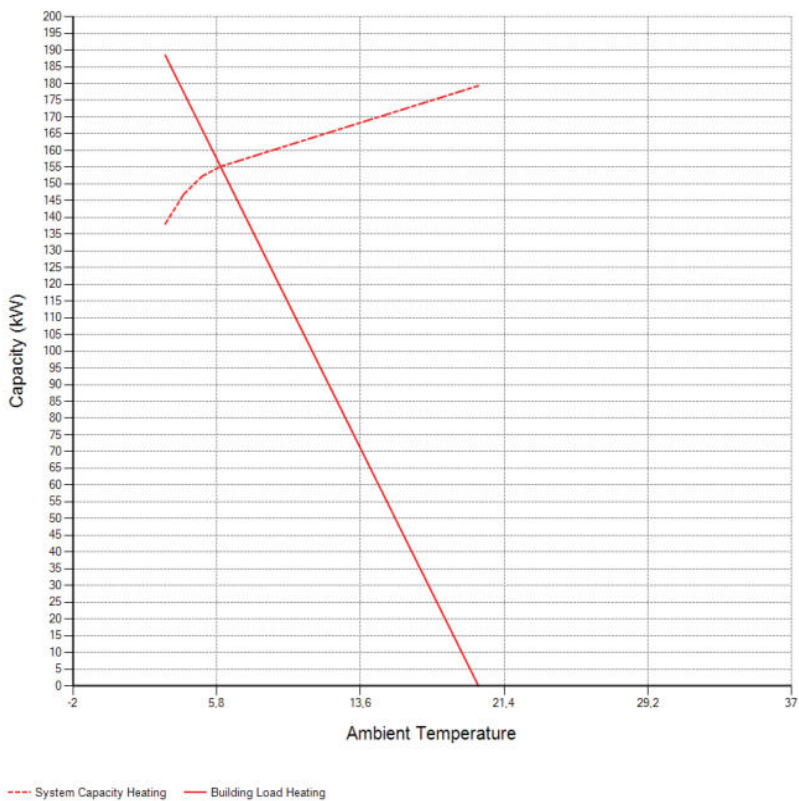

System information	
Indoor Units	11 of 64
Capacity Ratio	113,0%
Total Pipe Length	108,00 m
Indoor Cap. Tot./Sen.	120,37 kW/81,24 kW
Indoor Cap. Heat.	155,20 kW
Building diversity	0%

Outdoor/Indoor Legend	
Unit Name	
Model Name	
Room Name	
⊖ Corrected capacity	Tot./Sens./ Heat.

Piping Legend	
Actual Length	
Liquid / Suction Gas diameters	
Note: It is the responsibility of the consultant or contractor, to verify and confirm that the equipment selection and system design is correct before installation.	

Branches Legend		
a	RBM-BY305E	(x7)
b	RBM-BY105E	(x2)
c	RBM-BY205E	(x1)

PMV Legend	
●	RBM-PMV0363E

## Sistema 1

Floor: TERRAZZA

Elevation: 0,00m

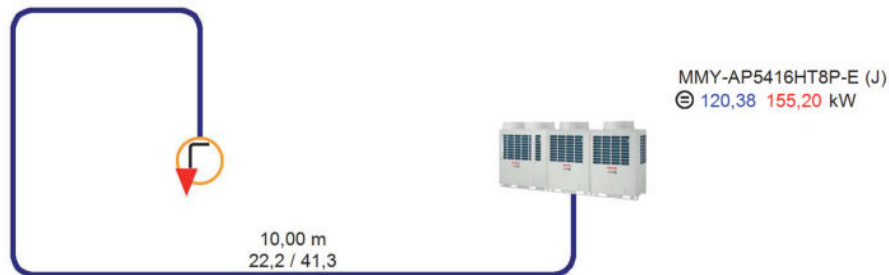

# Schematic Overview

System information	
Indoor Units	11 of 64
Capacity Ratio	113,0%
Total Pipe Length	108,00 m
Indoor Cap. Tot./Sen.	120,37 kW/81,24 kW
Indoor Cap. Heat.	155,20 kW
Building diversity	0%

Outdoor/Indoor Legend	
Unit Name	
Model Name	
Room Name	
⊖ Corrected capacity	Tot./Sens./ Heat.

Piping Legend	
Actual Length	
Liquid / Suction Gas diameters	
Note: It is the responsibility of the consultant or contractor, to verify and confirm that the equipment selection and system design is correct before installation.	

Branches Legend		
a	RBM-BY305E	(x7)
b	RBM-BY105E	(x2)
c	RBM-BY205E	(x1)

PMV Legend	
●	RBM-PMV0363E

## Sistema 1

Floor: SALA REGIA

Elevation: Above Outdoor Unit -15,00m

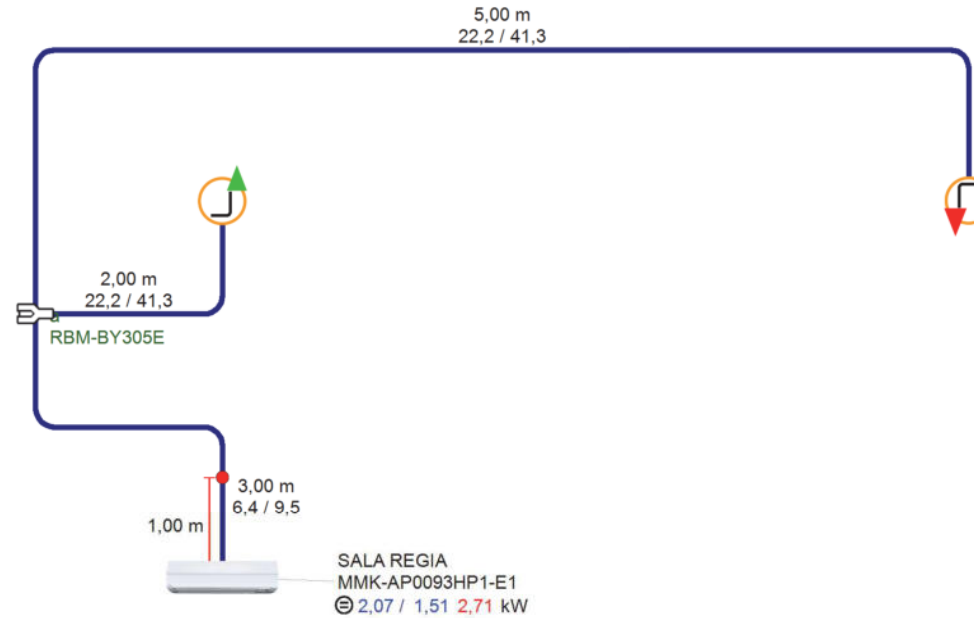

# Schematic Overview

## Sistema 1

Floor: SALA TEATRO

Elevation: Above Outdoor Unit -20,00m

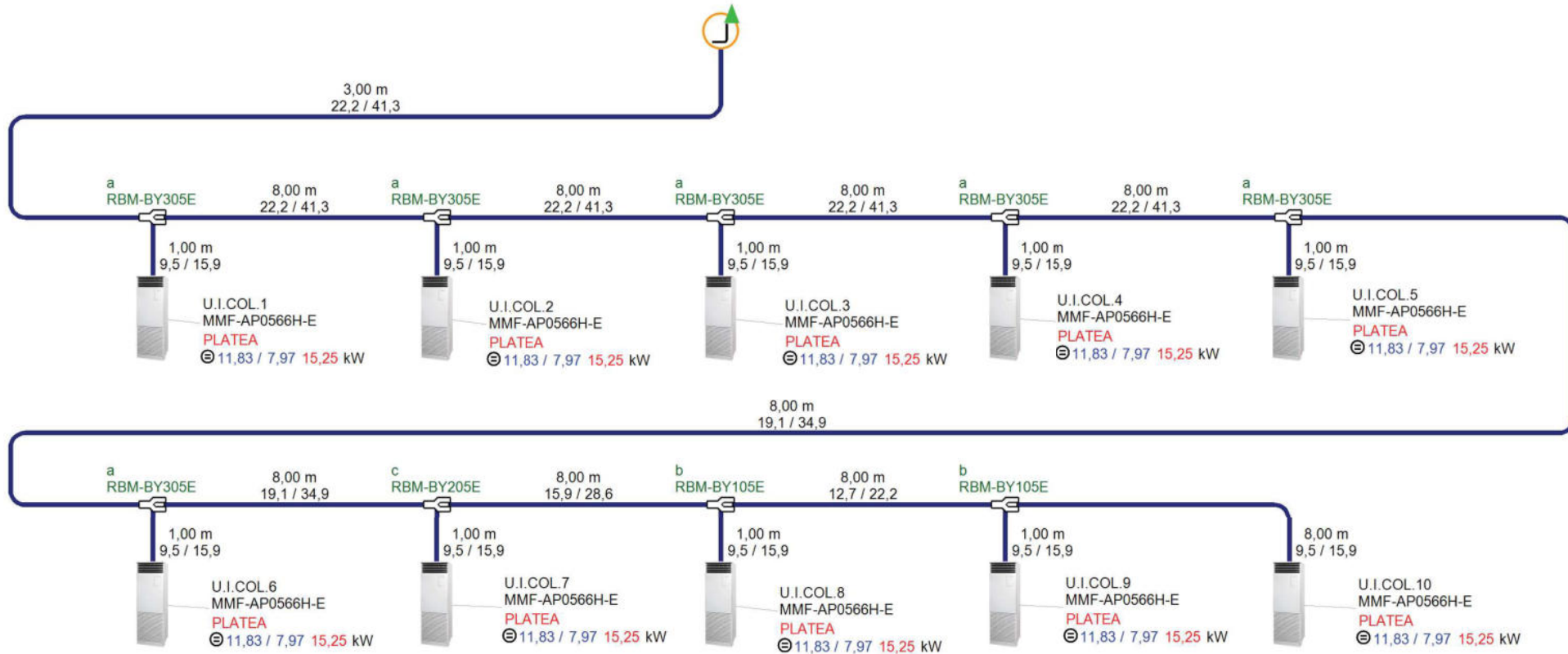

### System information

Indoor Units	11 of 64
Capacity Ratio	113,0%
Total Pipe Length	108,00 m
Indoor Cap. Tot./Sen.	120,37 kW/81,24 kW
Indoor Cap. Heat.	155,20 kW
Building diversity	0%

### Outdoor/Indoor Legend

Unit Name	
Model Name	
Room Name	
⊖ Corrected capacity	Tot./Sens./ Heat.

### Piping Legend

Actual Length	
Liquid / Suction Gas diameters	
Note:	It is the responsibility of the consultant or contractor, to verify and confirm that the equipment selection and system design is correct before installation.

### Branches Legend

a	RBM-BY305E	(x7)
b	RBM-BY105E	(x2)
c	RBM-BY205E	(x1)

### PMV Legend

●	RBM-PMV0363E
---	--------------

## Sistema 1

MMY-AP5416HT8P-E (J)

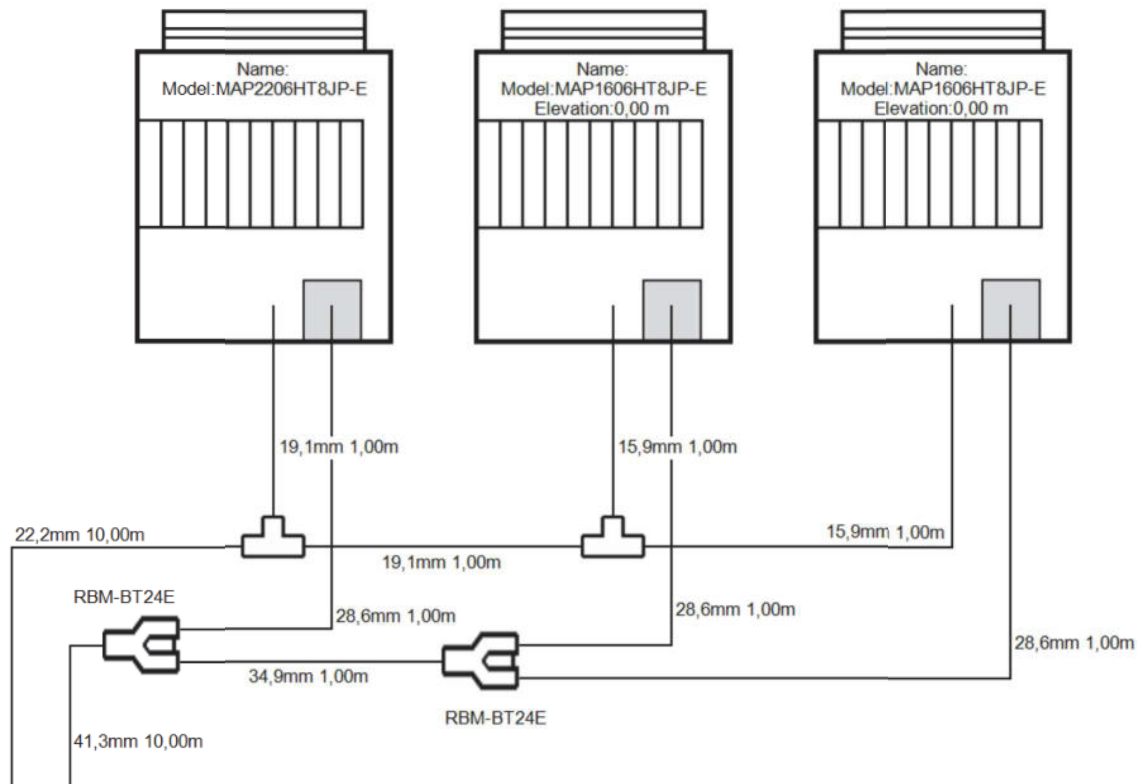

### Accessories

Header

Follower1

Follower2

Follower3

Follower4

### Electrical Information

Summary: 3N AC+Earth 380-415V 50Hz

- Slot 1
- Slot 2
- Slot 3
- Slot 4
- Slot 5

# System Wiring Diagram

## Sistema 1

Floor: TERRAZZA Elevation: 0,00m

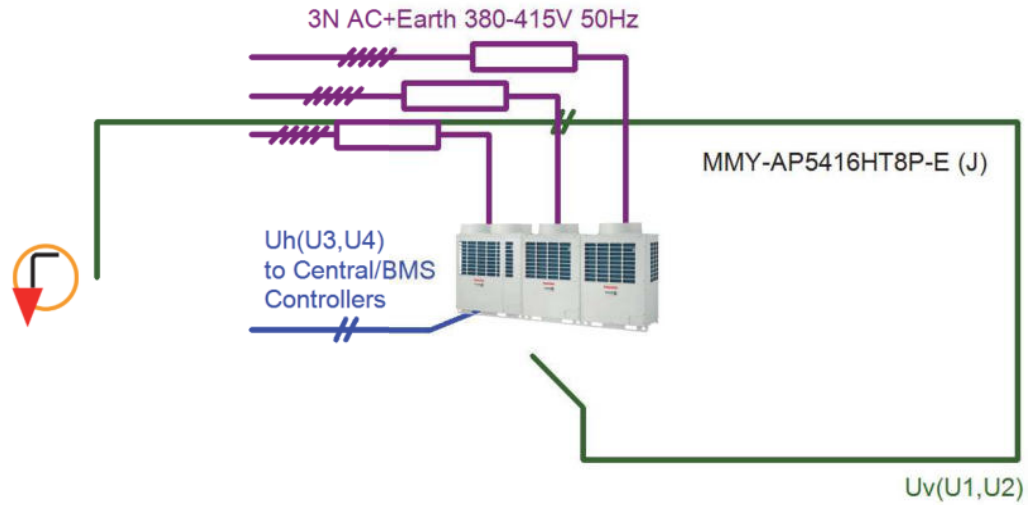



# System Wiring Diagram

## Sistema 1

Floor: SALA REGIA Elevation: Above Outdoor Unit -15,00m

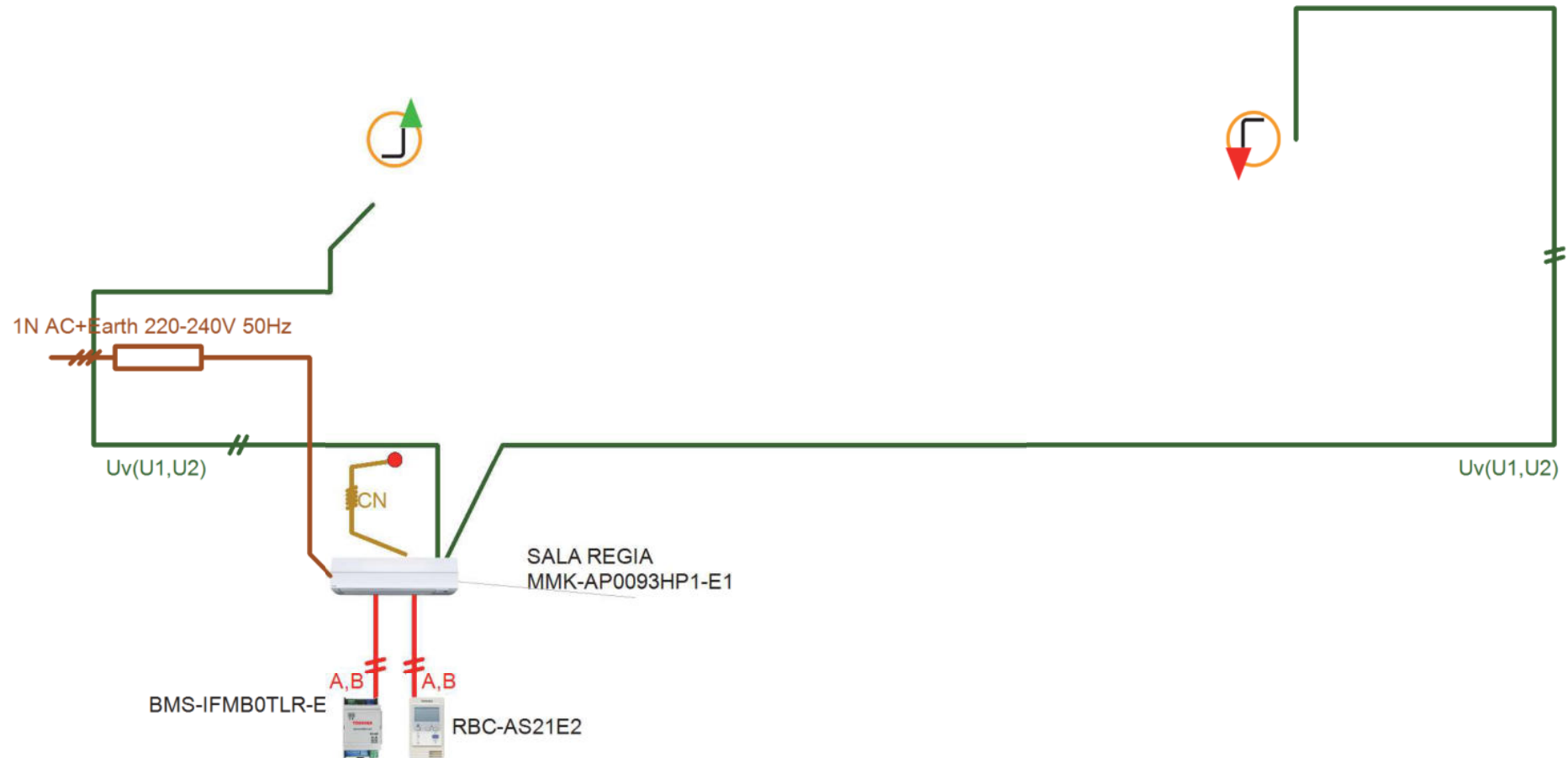

# System Wiring Diagram

## Sistema 1

Floor: SALA TEATRI Elevation: Above Outdoor Unit -20,00m

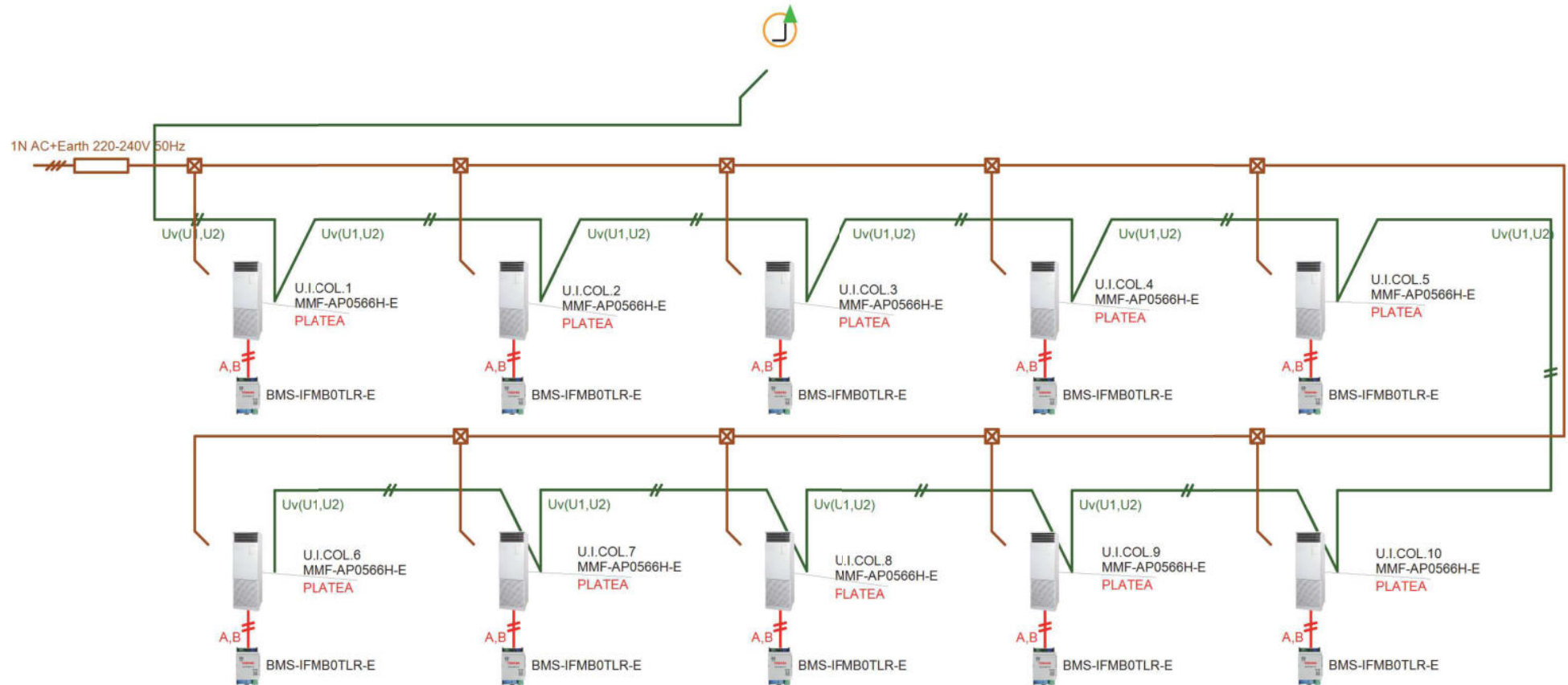

# Piping & Wiring Diagram

Control Wiring Legend	Label	Wiring Size and Length
Outdoor - Indoor Control Wiring*	Uv(U1, U2)	1,25mm <sup>2</sup> up to 1000m & 2,0mm <sup>2</sup> up to 2000m
Central Control Wiring*	Uh(U3, U4)	1,25mm <sup>2</sup> up to 1000m & 2,0mm <sup>2</sup> up to 2000m
Outdoor Units Control Wiring*	Uc(U5, U6)	1,25mm <sup>2</sup> to 2,0mm <sup>2</sup> up to 100m
Remote Controller Wiring*	A, B	0,5mm <sup>2</sup> to 2,0mm <sup>2</sup> up to 500m (Wireless Remote Controller up to 400m). Group Control wiring is up to 200m

\* 2 core, no polarity, shielded  
 Note: Power Wiring should comply with Local, National and International Regulation.

Symbol Legend		
Control		
Power		
Remote Control		
Signal		
Piping*		
*Note: Pipe diameters in mm		
Branches Legend		
RBM-BY305E	a	(x7)
RBM-BY105E	b	(x2)
RBM-BY205E	c	(x1)
PMV Legend		
RBM-PMV0363E		(x1)

**Sistema 1**  
 Floor: TERRAZZA Elevation: 0,00m

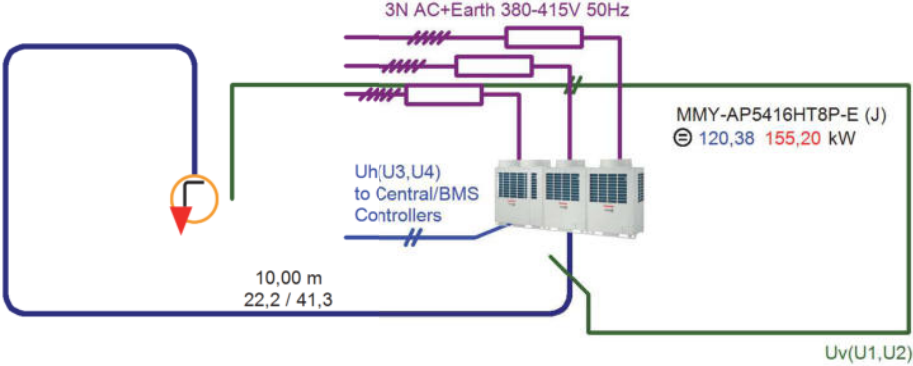

# Piping & Wiring Diagram

Control Wiring Legend	Label	Wiring Size and Length
Outdoor - Indoor Control Wiring*	Uv(U1, U2)	1,25mm <sup>2</sup> up to 1000m & 2,0mm <sup>2</sup> up to 2000m
Central Control Wiring*	Uh(U3, U4)	1,25mm <sup>2</sup> up to 1000m & 2,0mm <sup>2</sup> up to 2000m
Outdoor Units Control Wiring*	Uc(U5, U6)	1,25mm <sup>2</sup> to 2,0mm <sup>2</sup> up to 100m
Remote Controller Wiring*	A, B	0,5mm <sup>2</sup> to 2,0mm <sup>2</sup> up to 500m (Wireless Remote Controller up to 400m). Group Control wiring is up to 200m

\* 2 core, no polarity, shielded  
 Note: Power Wiring should comply with Local, National and International Regulation.

**Sistema 1**  
 Floor: SALA REGIA/ Elevation: Above Outdoor Unit -15,00m

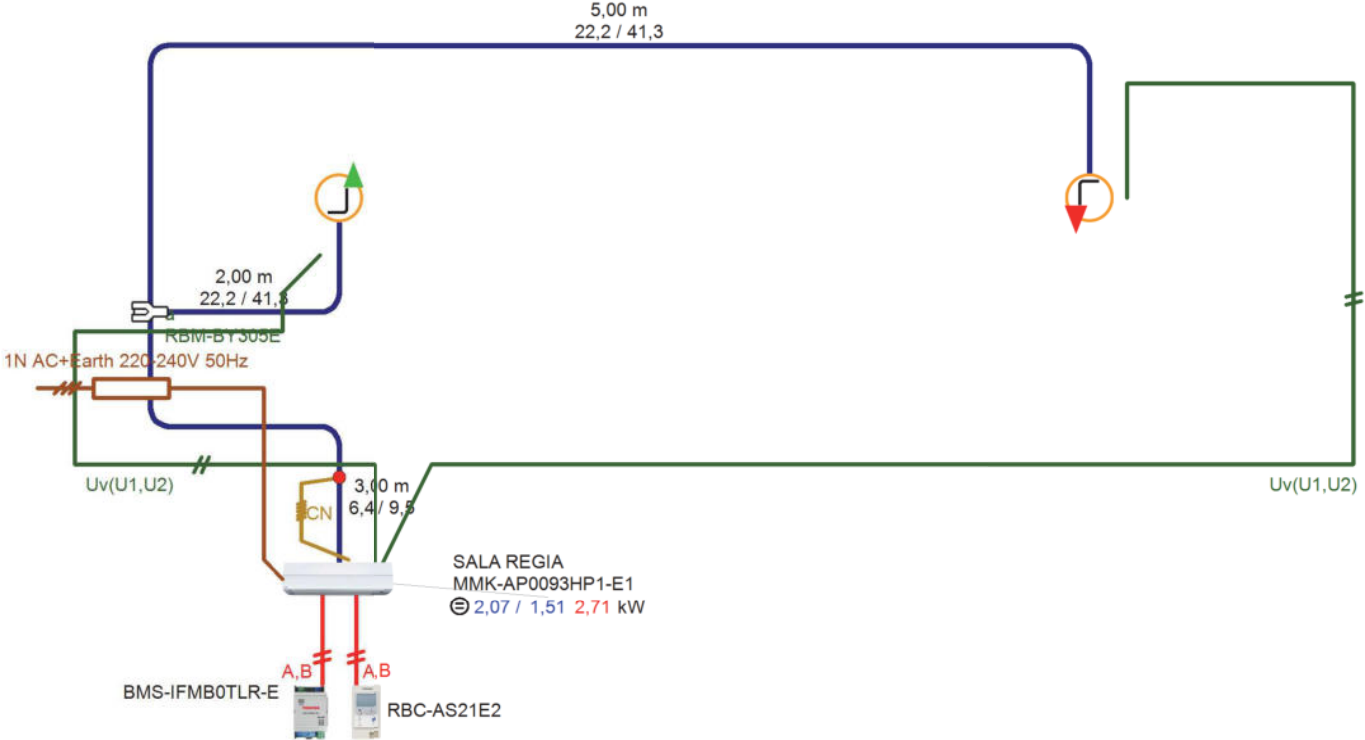

# Piping & Wiring Diagram

Control Wiring Legend	Label	Wiring Size and Length
Outdoor - Indoor Control Wiring*	Uv(U1, U2)	1,25mm <sup>2</sup> up to 1000m & 2,0mm <sup>2</sup> up to 2000m
Central Control Wiring*	Uh(U3, U4)	1,25mm <sup>2</sup> up to 1000m & 2,0mm <sup>2</sup> up to 2000m
Outdoor Units Control Wiring*	Uc(U5, U6)	1,25mm <sup>2</sup> to 2,0mm <sup>2</sup> up to 100m
Remote Controller Wiring*	A, B	0,5mm <sup>2</sup> to 2,0mm <sup>2</sup> up to 500m (Wireless Remote Controller up to 400m). Group Control wiring is up to 200m

\* 2 core, no polarity, shielded  
 Note: Power Wiring should comply with Local, National and International Regulation.

## Sistema 1

Floor: SALA TEAT Elevation: Above Outdoor Unit -20,00m

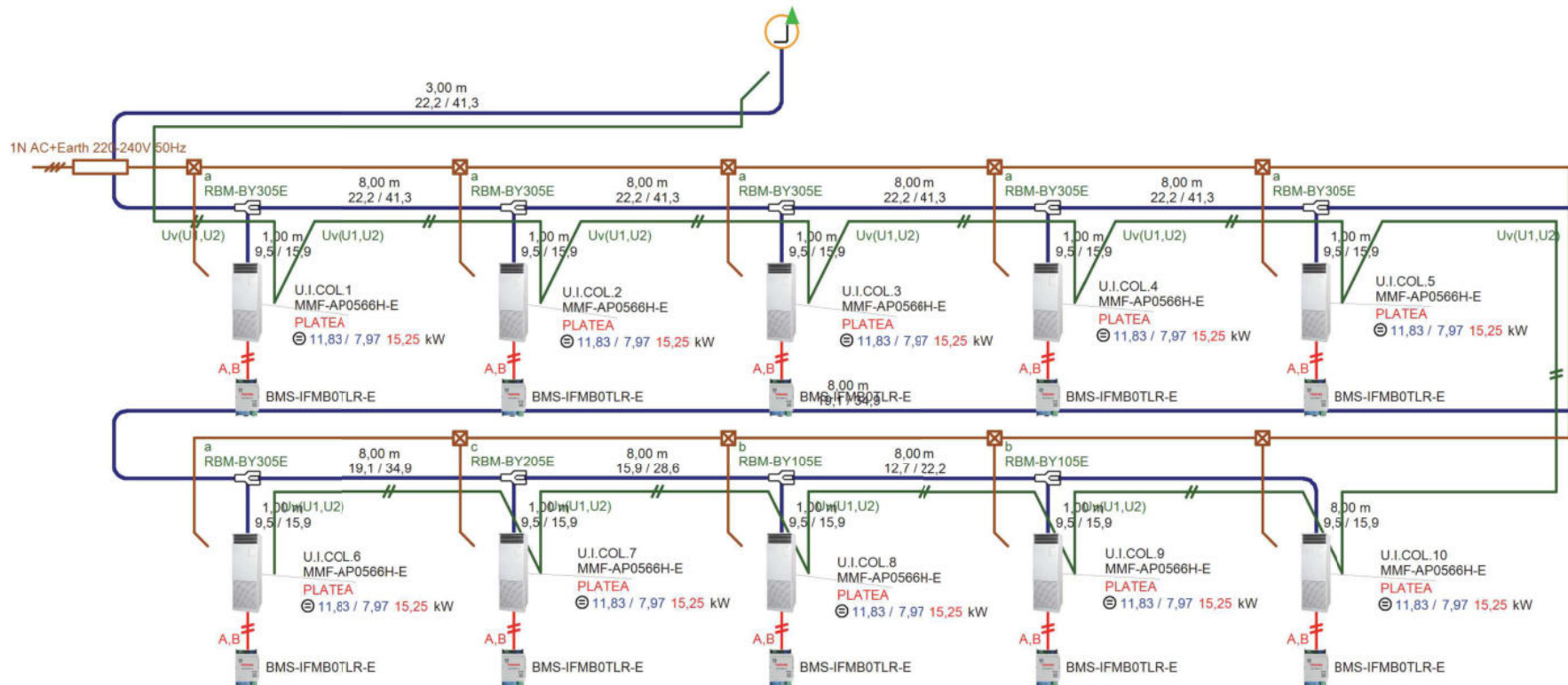

# Control Wiring Diagram

## Sistema 1

Floor: TERRAZZA Elevation: 0,00m

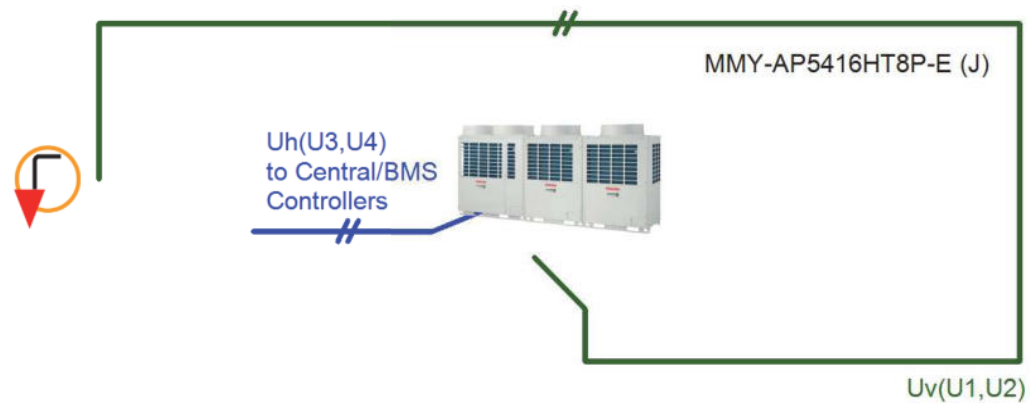

# Control Wiring Diagram

## Sistema 1

Floor: SALA REGIA Elevation: Above Outdoor Unit -15,00m

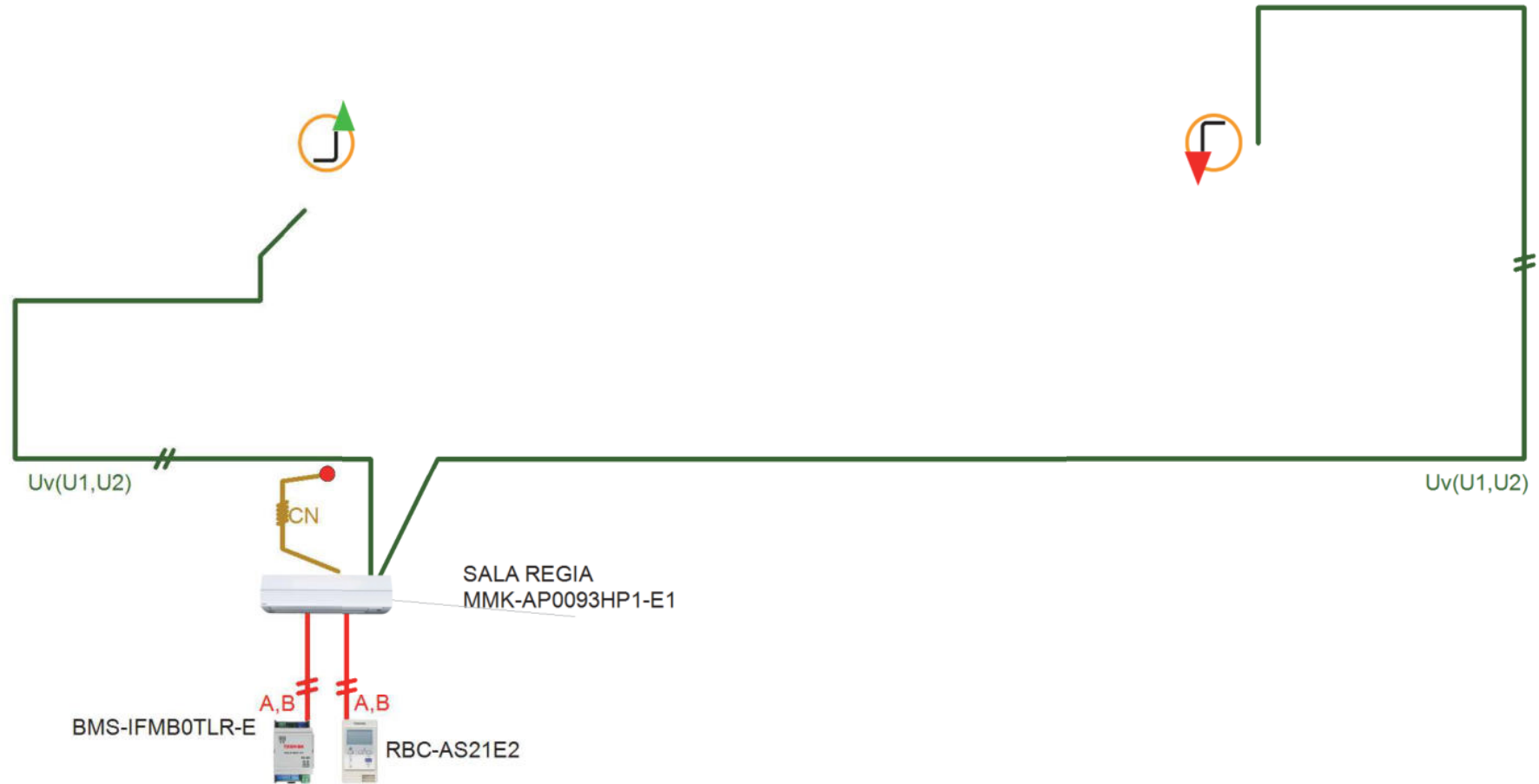

# Control Wiring Diagram

## Sistema 1

Floor: SALA TEATRI Elevation: Above Outdoor Unit -20,00m

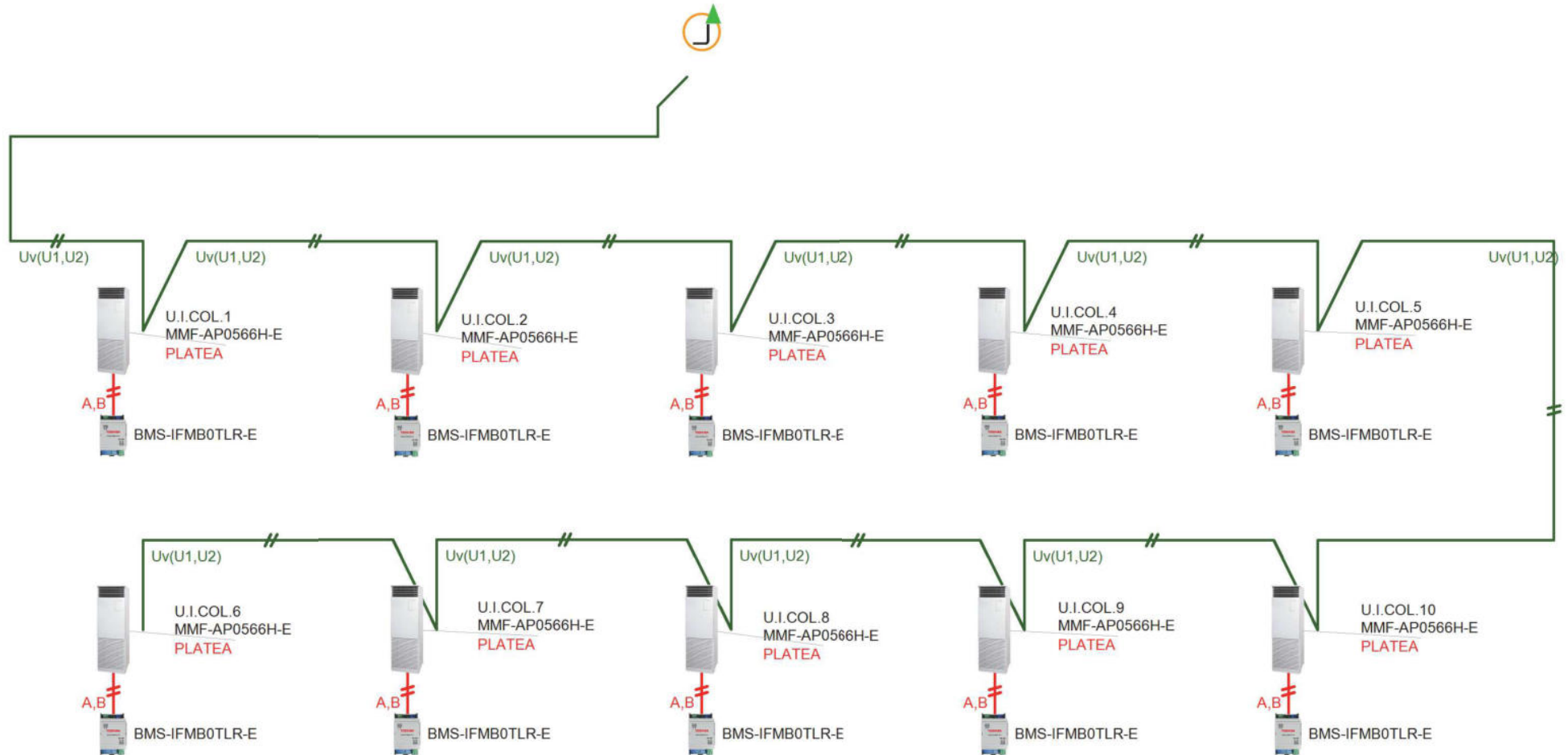



# Power Wiring Diagram

## Sistema 1

Floor: TERRAZZA Elevation: 0,00m

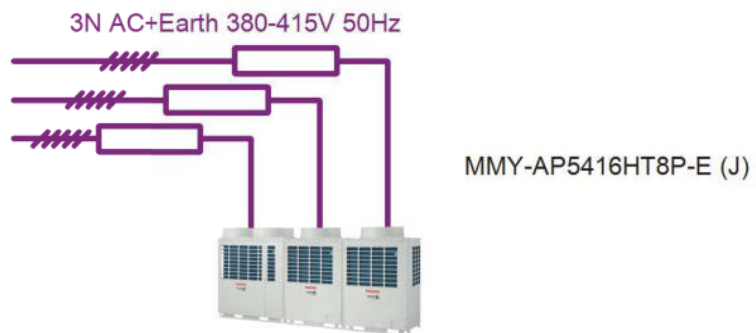

# Power Wiring Diagram

## Sistema 1

Floor: SALA REGIA Elevation: Above Outdoor Unit -15,00m



1N AC+Earth 220-240V 50Hz

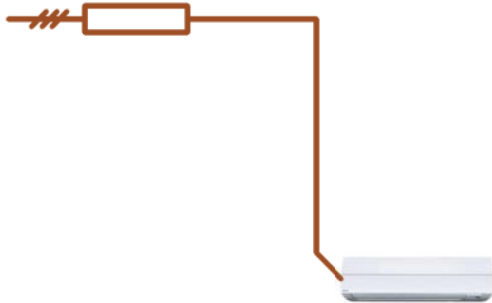

SALA REGIA  
MMK-AP0093HP1-E1

# Power Wiring Diagram

## Sistema 1

Floor: SALA TEATRI Elevation: Above Outdoor Unit -20,00m



## Sistema 1

Model:	Sistema 1	System type	Tall Floor Standing
Model name	MMY-AP5416HT8P-E	Season	Average
Outdoor heat exchanger:	-		
Indoor heat exchanger:	-	SEER(A)	4,88
type:	-		
compressor driver:	-	SCOP(A)	3,62

### COOLING

Item	Symbol	Value	Unit	Item	Symbol	Value	Unit
Rated cooling capacity	Prated,c	151,5	kW	Seasonal space cooling energy efficiency	$\eta_{s,c}$ (A)	192,2	%
					$\eta_{s,c}$ (C)	190,4	%
					$\eta_{s,c}$ (W)	194,0	%

Declared cooling capacity for part load at given outdoor temperatures  $T_j$  and indoor  $27^\circ/19^\circ\text{C}$  (dry/wet bulb)

$T_j = +35^\circ\text{C}$	Pdc	151,50	kW
$T_j = +30^\circ\text{C}$	Pdc	112,53	kW
$T_j = +25^\circ\text{C}$	Pdc	71,08	kW
$T_j = +20^\circ\text{C}$	Pdc	33,34	kW

Declared energy efficiency ratio or gas utilisation efficiency/auxiliary energy factor for part load at given outdoor

$T_j = +35^\circ\text{C}$	EERd	2,01	-
$T_j = +30^\circ\text{C}$	EERd	3,79	-
$T_j = +25^\circ\text{C}$	EERd	5,99	-
$T_j = +20^\circ\text{C}$	EERd	8,63	-

Degradation co-efficient for air conditioners(\*)

Cdc	-	-
-----	---	---

### HEATING

Item	Symbol	Value	Unit	Item	Symbol	Value	Unit
Rated heating capacity	Prated,c	164,0	kW	Seasonal space heating energy efficiency	$\eta_{s,h}$ (A)	141,8	%
					$\eta_{s,h}$ (C)	103,5	%
					$\eta_{s,h}$ (W)	220,8	%

Declared heating capacity for part load at given outdoor temperatures  $T_j$  and indoor  $27^\circ/19^\circ\text{C}$  (dry/wet bulb)

$T_j = -7^\circ\text{C}$	Pdh	96,42	kW
$T_j = +2^\circ\text{C}$	Pdh	60,95	kW
$T_j = +7^\circ\text{C}$	Pdh	37,42	kW
$T_j = +12^\circ\text{C}$	Pdh	20,22	kW
Tbiv = bivalent temperature	Pdh	96,42	kW
TOL = operation limit	Pdh	68,88	kW
$T_j = -15^\circ\text{C}$ (if TOL < $-20^\circ\text{C}$ )	Pdh	92,28	kW
Bivalent temperature	Tbiv	-	$^\circ\text{C}$

Declared energy efficiency ratio or gas utilisation efficiency/auxiliary energy factor for part load at given outdoor

$T_j = -7^\circ\text{C}$	COPd	2,30	-
$T_j = +2^\circ\text{C}$	COPd	3,26	-
$T_j = +7^\circ\text{C}$	COPd	5,57	-
$T_j = +12^\circ\text{C}$	COPd	6,18	-
Tbiv = bivalent temperature	COPd	2,30	-
TOL = operation limit	COPd	1,38	-
$T_j = -15^\circ\text{C}$ (if TOL < $-20^\circ\text{C}$ )	COPd	1,79	-
Minimum operation temperature	Tol	-	$^\circ\text{C}$

Degradation co-efficient for air conditioners(\*)

Cdc	-	-
-----	---	---

#### Power consumption in modes other than "active mode"

Off mode	POFF	0,045	kW	Back-up heating capacity	PCK	#####	kW
Thermostat-off mode	PTO	-	kW	Type of energy input	-	-	
Crankcase heater mode	PCK	0,345	kW	Standby mode	PSB	0,045	kW

#### Other items

Capacity control	-						
Sound power level, indoor/outdoor measured outdoor unit	LWA	84	dB	For air-to-air air conditioner: air flow rate, outdoor measured	-	18500	m <sup>3</sup> /h
outdoor unit	LWA	83	dB	outdoor unit		12600	m <sup>3</sup> /h
outdoor unit	LWA	83	dB	outdoor unit		12600	m <sup>3</sup> /h
If engine driven: Emissions of nitrogen oxides	NOx	-	mg/kWh fuel input	For water/brine-to-air heat pumps: Rated brine or water flow rate, outdoor side	-	-	m <sup>3</sup> /h
GWP of the refrigerant	-		kg CO2 eq (100 years)	heat exchanger			
Contact Details	-						

# Part Load Table

MMY-AP5416HT8P-E (54HP, 151,50kW system)

Cooling		Compressor + Outdoor Fan Power consumption (kW)																	
Outdoor Unit		Outdoor Unit 100% Capacity		100%		90%		80%		70%		60%		50%		40%		30%	
°C	(kW)	TC	PI	TC	PI	TC	PI	TC	PI	TC	PI	TC	PI	TC	PI	TC	PI	TC	PI
		(kW)	(kW)	(kW)	(kW)	(kW)	(kW)	(kW)	(kW)	(kW)	(kW)	(kW)	(kW)	(kW)	(kW)	(kW)	(kW)	(kW)	(kW)
40,0 °C	141	141	56,0	127	44,3	113	34,6	98,7	26,6	84,6	20,1	70,5	14,8	56,4	10,6	42,3	7,06		
39,0 °C	143	143	55,1	129	43,7	115	34,1	100	26,2	86,0	19,8	71,6	14,6	57,3	10,4	43,0	6,96		
37,0 °C	148	148	53,5	133	42,3	118	33,1	103	25,5	88,5	19,2	73,8	14,2	59,0	10,1	44,3	6,75		
35,0 °C	151	151	51,8	136	41,0	121	32,0	106	24,6	90,9	18,6	75,7	13,7	60,6	9,77	45,4	6,53		
33,0 °C	152	152	47,5	136	37,7	121	29,5	106	22,8	90,9	17,3	75,8	12,8	60,6	9,13	45,4	6,12		
31,0 °C	152	152	43,7	136	34,8	121	27,3	106	21,2	90,9	16,1	75,8	11,9	60,6	8,55	45,4	5,74		
30,0 °C	152	152	42,0	136	33,5	121	26,3	106	20,4	90,9	15,5	75,8	11,5	60,6	8,28	45,4	5,56		
29,0 °C	152	152	40,4	136	32,2	121	25,4	106	19,7	90,9	15,0	75,8	11,2	60,6	8,02	45,4	5,39		
27,0 °C	152	152	37,4	136	29,9	121	23,6	106	18,4	90,9	14,0	75,8	10,5	60,6	7,53	45,4	5,07		
25,0 °C	152	152	34,8	136	27,8	121	22,0	106	17,1	90,9	13,1	75,8	9,82	60,6	7,08	45,4	4,77		
23,0 °C	152	152	33,1	136	26,5	121	21,0	106	16,4	90,9	12,6	75,8	9,42	60,6	6,80	45,4	4,58		
21,0 °C	152	152	32,2	136	25,9	121	20,5	106	16,0	90,9	12,3	75,8	9,25	60,6	6,68	45,4	4,51		
20,0 °C	152	152	31,9	136	25,6	121	20,3	106	15,9	90,9	12,2	75,8	9,17	60,6	6,63	45,4	4,48		
19,0 °C	152	152	31,5	136	25,3	121	20,1	106	15,8	90,9	12,1	75,8	9,10	60,6	6,59	45,4	4,45		
17,0 °C	152	152	30,9	136	24,9	121	19,8	106	15,5	90,9	11,9	75,8	8,98	60,6	6,50	45,4	4,39		
15,0 °C	152	152	30,4	136	24,5	121	19,5	106	15,3	90,9	11,8	75,8	8,87	60,6	6,43	45,4	4,35		

TC : Total Capacity      PI : Power Input  
 Indoor air temperature conditions : 27,0°C dry-bulb / 19,0°C wet bulb

Heating			Compressor + Outdoor Fan Power consumption (kW)															
Outdoor Unit		Outdoor Unit 100% Heating Capacity (kW)	100% Capacity		90% Capacity		80% Capacity		70% Capacity		60% Capacity		50% Capacity		40% Capacity		30% Capacity	
Dry-Bulb (°C)	Wet-Bulb (°C)		TC	PI	TC	PI	TC	PI	TC	PI	TC	PI	TC	PI	TC	PI	TC	PI
			(kW)	(kW)	(kW)	(kW)	(kW)	(kW)	(kW)	(kW)	(kW)	(kW)	(kW)	(kW)	(kW)	(kW)	(kW)	(kW)
15,0	13,7	164	164	35,4	148	29,7	131	24,7	115	20,5	98,4	16,8	82,0	13,7	65,6	10,9	49,2	8,30
13,0	11,8	164	164	37,0	148	30,9	131	25,6	115	21,2	98,4	17,3	82,0	14,0	65,6	11,1	49,2	8,47
11,0	9,80	164	164	38,8	148	32,3	131	26,7	115	22,0	98,4	17,9	82,0	14,4	65,6	11,4	49,2	8,67
9,00	7,90	164	164	40,8	148	33,7	131	27,8	115	22,8	98,4	18,5	82,0	14,9	65,6	11,7	49,2	8,86
7,00	6,00	164	164	42,9	148	35,4	131	29,0	115	23,7	98,4	19,1	82,0	15,3	65,6	12,0	49,2	9,08
5,00	4,10	158	158	42,6	142	35,1	126	28,8	111	23,5	94,9	19,0	79,1	15,2	63,2	11,9	47,4	9,01
3,00	2,20	152	152	42,2	137	34,8	122	28,6	107	23,3	91,4	18,9	76,1	15,1	60,9	11,8	45,7	8,94
0,00	-0,70	143	143	41,7	129	34,4	115	28,2	100	23,0	86,0	18,6	71,6	14,9	57,3	11,7	43,0	8,83
-3,00	-3,70	134	134	41,2	121	34,0	107	27,9	93,8	22,7	80,4	18,4	67,0	14,7	53,6	11,5	40,2	8,72
-5,00	-5,60	128	128	40,9	115	33,7	103	27,7	89,7	22,6	76,9	18,3	64,1	14,6	51,3	11,5	38,4	8,65
-7,00	-7,60	122	122	40,6	110	33,5	97,6	27,4	85,4	22,4	73,2	18,1	61,0	14,5	48,8	11,4	36,6	8,58
-10,0	-10,5	113	113	40,1	102	33,0	90,4	27,1	79,1	22,1	67,8	17,9	56,5	14,3	45,2	11,2	33,9	8,48
-14,5	-15,0	99,1	99,1	39,3	89,2	32,4	79,3	26,6	69,4	21,7	59,5	17,5	49,5	14,0	39,6	11,0	29,7	8,31

TC : Total Capacity      PI : Power Input  
 Indoor air temperature conditions : 20,0°C dry-bulb

# System Equipment List

## Sistema 2

### Outdoor Units

Model	Quantity	Description
MMY-AP4216HT8P-E	1	Super Modular Multi System (SMMS-e)
MMY-MAP2006HT8P-E		Super Modular Multi System (SMMS-e)
MMY-MAP2206HT8P-E		Super Modular Multi System (SMMS-e)

### DX Kit Item

Model	Quantity	Description
MM-DXC010	1	DX Controller
MM-DXC012	4	DX Controller
MM-DXV280	5	DX Valve Kit

### Y Joints

Model	Quantity	Description
RBM-BT24E	1	Outdoor Unit Branch Kit
RBM-BY305E	3	Y-Joint
RBM-BY205E	1	Y-Joint

### Accessories

Model	Quantity	Description
TCB-PCDM4E	1	Power peak-cut Control
TCB-PCMO4E	2	Operation mode selection control
TCB-PCIN4E	2	Compressor Operation Output
TCB-EXS21TLE	1	Schedule timer

### Piping Length

Pipe Diameter	Total Length	Gas Side	Discharge Side	Liquid Side
12,7mm	10,00 m	0,00 m	0,00 m	10,00 m
15,9mm	4,00 m	0,00 m	0,00 m	4,00 m
19,1mm	18,00 m	4,00 m	0,00 m	14,00 m
22,2mm	8,00 m	6,00 m	0,00 m	2,00 m
28,6mm	6,00 m	6,00 m	0,00 m	0,00 m
34,9mm	2,00 m	2,00 m	0,00 m	0,00 m
41,3mm	12,00 m	12,00 m	0,00 m	0,00 m

### Total Refrigerant Charge Amount

Refrigerant (R410A)	Amount	Description
Outdoor Unit	23,000 kg	Refrigerant amount charged in factory
Additional Refrigerant	28,468 kg	Amount needed for the pipes at the site
<b>TOTAL:</b>	<b>51,468 kg</b>	

### Outdoor Design Temperature

Mode	Description	Temperature
Cooling	Dry Bulb temperature	35,0 °C
Heating	Wet Bulb temperature	6,0 °C

### Electronic Information(OutdoorUnits)

Property	Value	Description
MOCP(A)	125	Maximum Overcurrent Protection
MCA(A)	94,2	Minimum Circuit Amps
Protection Device Size(A)		Follow applicable local standard as needed
Wire(cable size)(mm <sup>2</sup> ) or AWG(#)		Follow applicable local standard as needed

# System Equipment List

---

## Electronic Information(IndoorUnits)

Property	Value	Description
Total MCA(A)	0	
Protection Device Size(A)		Follow applicable local standard as needed
Wire(cable size)(mm <sup>2</sup> ) or AWG(#)		Follow applicable local standard as needed

## System Details

### Sistema 2

#### Outdoor Unit

Model Name	Cooling (kW)		Heating (kW)		Diversity	
	Rated	Corrected	Rated	Corrected	System	Building
MMY-AP4216HT8P-E	117,50	120,24	127,00	130,43	109,5%	0%

#### Outdoor Unit Combination

Header	Follower1	Follower2	Follower3	Follower4
MMY-MAP2206HT8P-E	MMY-MAP2006HT8P-E			

#### Indoor Units

Model Name	UnitName &Room	Capacity Code	Fan Speed Air flow (m³/h)	Mode	Capacity (Total/Sensible) [kW]		
					Rated	Corrected	Required
MM-46HP DXC010 & DX	COMANDO UT/ SALA TEATRO	46	High	Cooling	130,00/0,00	120,24/0,00	75,00/30,00
				Heating	145,00	130,43	95,00

#### Floor Information

Floors	Room Name	Indoor Units			Design Conditions		
		Name	Model	Mode	DB[°C]	WB[°C]	RH[%]
PIANO TERRAZ	SALA TEATRO	COMANDO UTA	MM-46HP DXC010 & DXC01	Cooling	27,0	19,6	50,00
				Heating	20,0		



# Seasonal Power Consumption

System Name Sistema 2

Average Daily Temperature

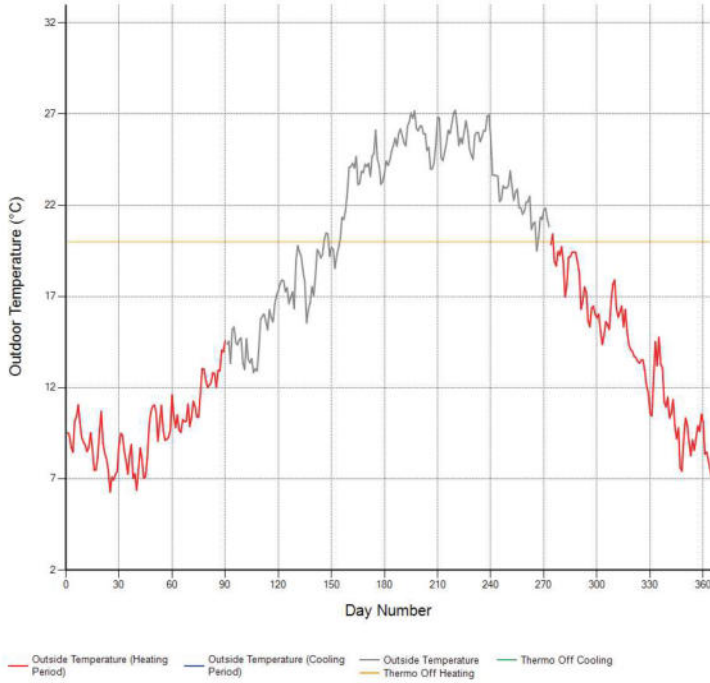

Yearly Outdoor Temperature Condition

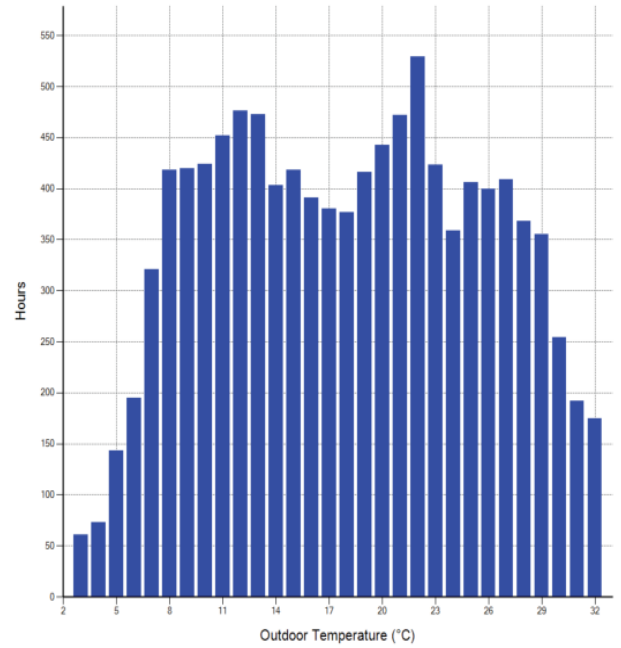

Capacity Trend

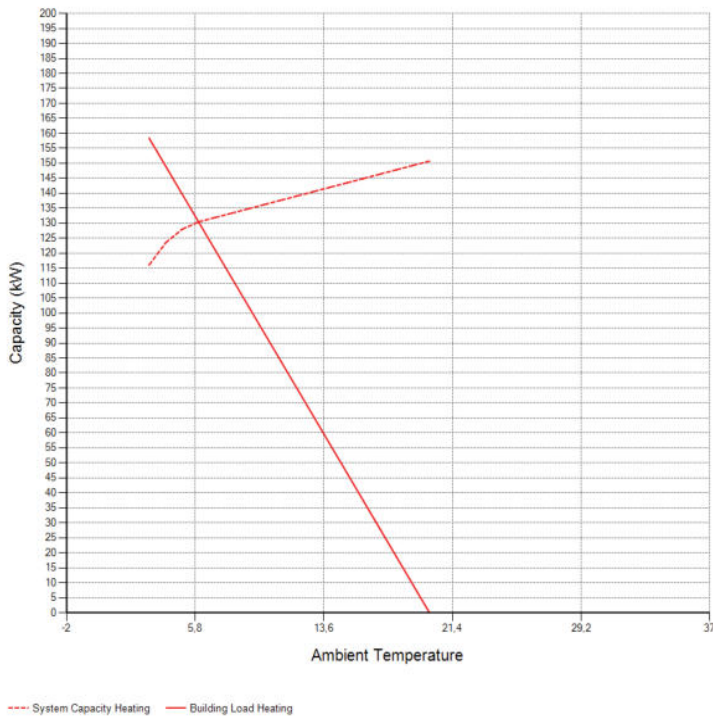

## System information

Indoor Units	1 of 64
Capacity Ratio	109,5%
Total Pipe Length	14,00 m
Indoor Cap. Tot./Sen.	120,24 kW/0,00 kW
Indoor Cap. Heat.	130,43 kW
Building diversity	0%

## Outdoor/Indoor Legend

Unit Name	
Model Name	
Room Name	
⊖ Corrected capacity	Tot./Sens./ Heat.

## Piping Legend

Actual Length  
Liquid / Suction Gas diameters  
Note: It is the responsibility of the consultant or contractor, to verify and confirm that the equipment selection and system design is correct before installation.

## Sistema 2

Floor: PIANO TERRAZZA Elevation: 0,00m

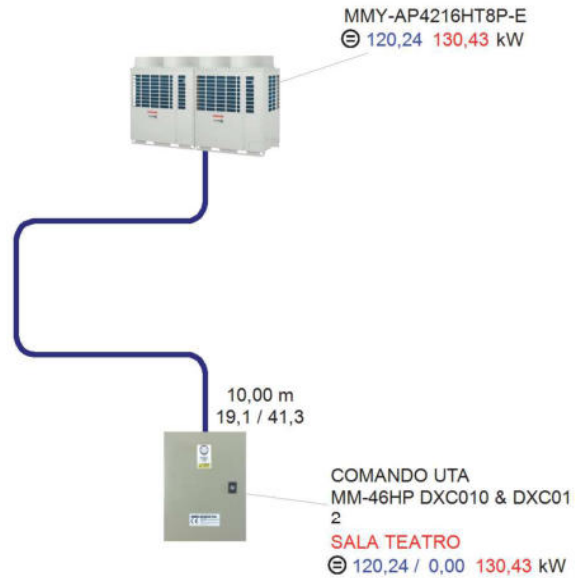

## Sistema 2

MMY-AP4216HT8P-E

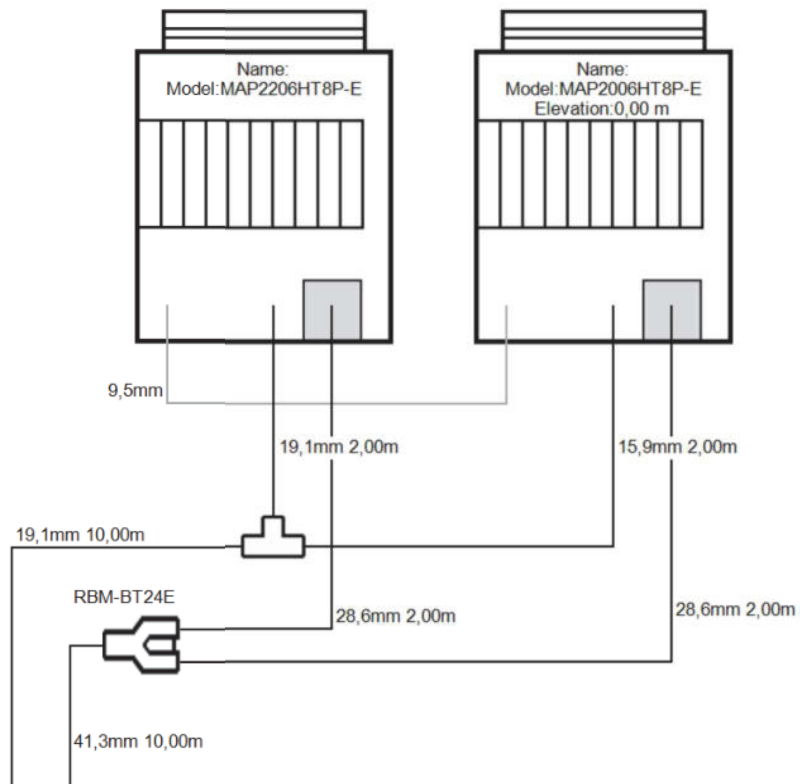

### Accessories

	Header	Follower1	Follower2	Follower3	Follower4
Slot 1	Power peak-cut Control				
Slot 2	Night time operation cor				
Slot 3	Compressor Operation ( Compressor Operation (				
Slot 4					
Slot 5	Operation mode selectic				

### Electrical Information

Summary: 3N AC+Earth 380-415V 50Hz

## Sistema 2

MM-46HP DXC010 & DXC012

### COMANDO UTA

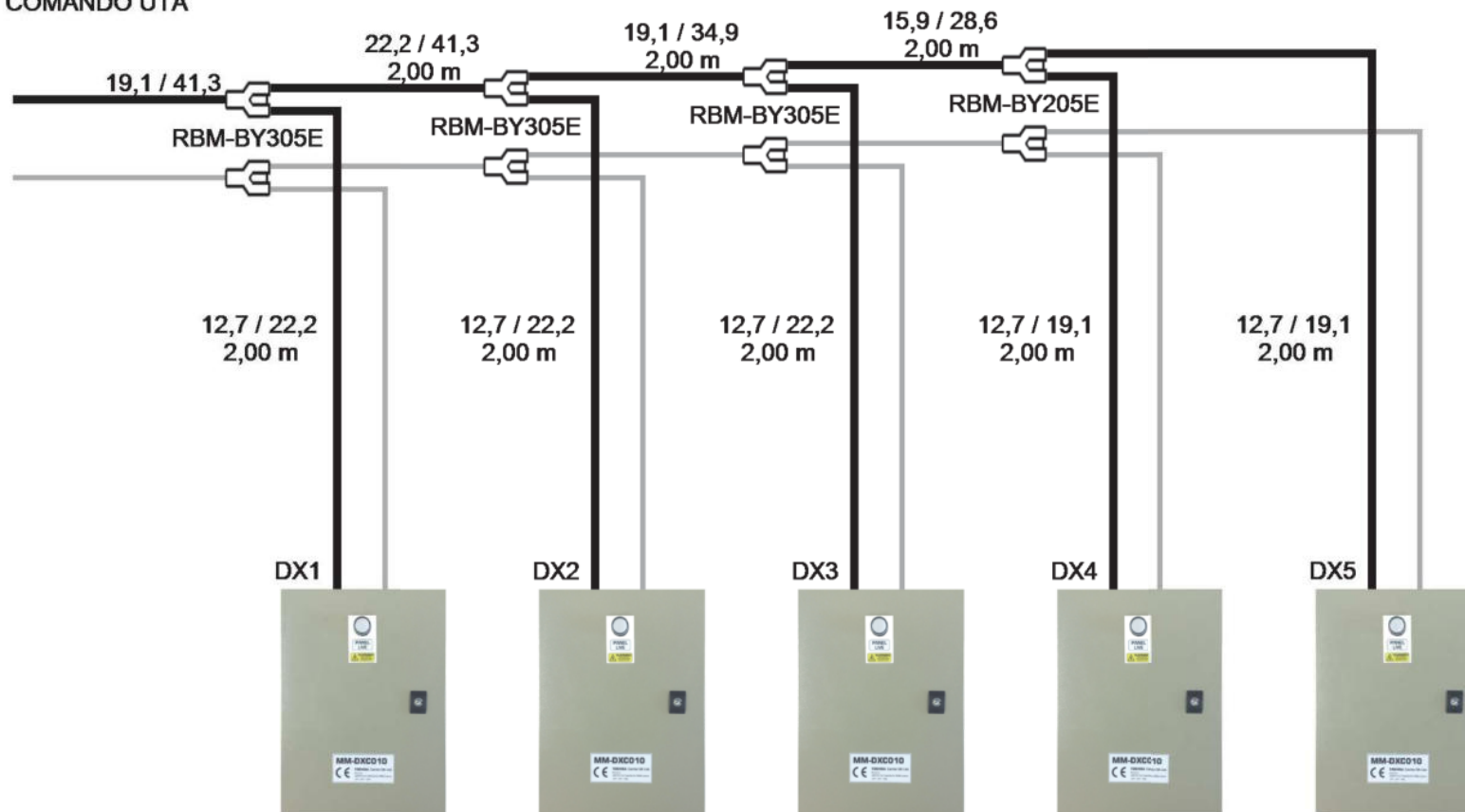

Size	10 HP	10 HP	10 HP	8 HP	8 HP
DX Control	MM-DXC010	MM-DXC012	MM-DXC012	MM-DXC012	MM-DXC012
DX Valve	MM-DXV280	MM-DXV280	MM-DXV280	MM-DXV280	MM-DXV280
Elevation	20,00 m	20,00 m	20,00 m	20,00 m	20,00 m
Name	DX1	DX2	DX3	DX4	DX5

# System Wiring Diagram

## Sistema 2

Floor: PIANO TER | Elevation: 0,00m

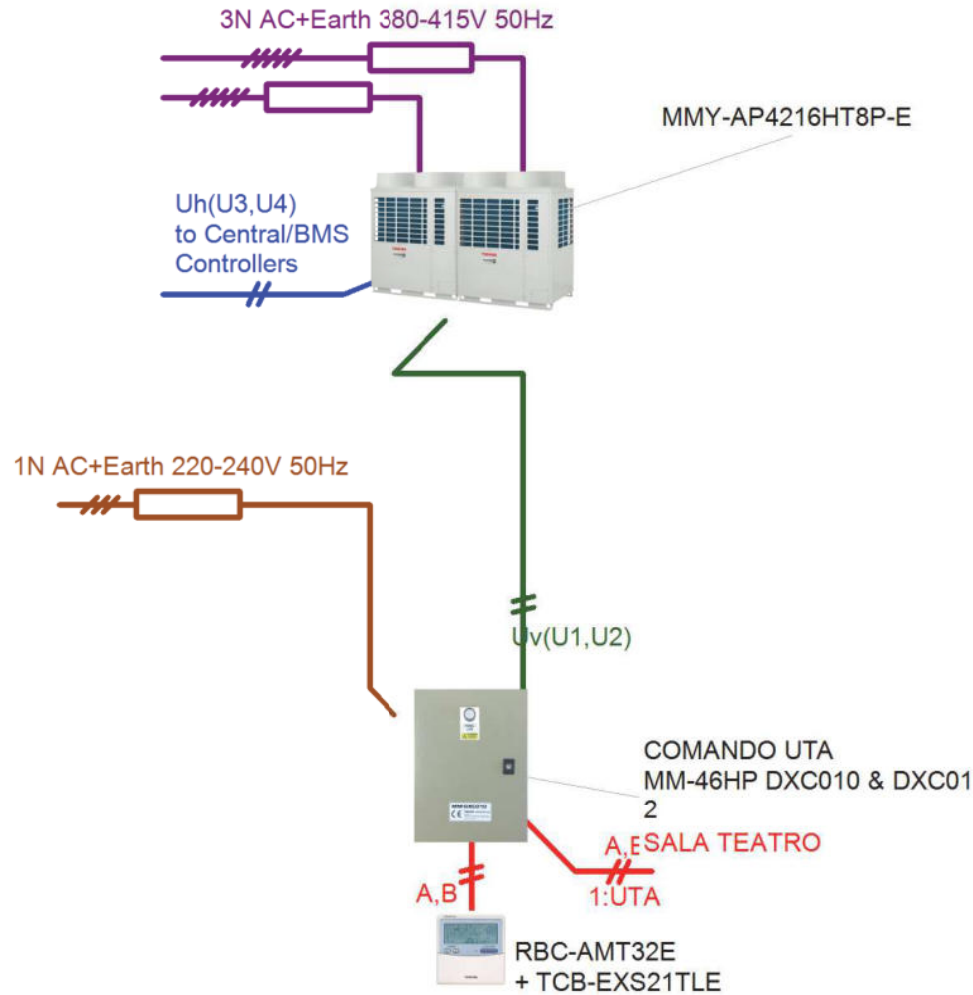

# Piping & Wiring Diagram

Control Wiring Legend	Label	Wiring Size and Length
Outdoor - Indoor Control Wiring*	Uv(U1, U2)	1,25mm <sup>2</sup> up to 1000m & 2,0mm <sup>2</sup> up to 2000m
Central Control Wiring*	Uh(U3, U4)	1,25mm <sup>2</sup> up to 1000m & 2,0mm <sup>2</sup> up to 2000m
Outdoor Units Control Wiring*	Uc(U5, U6)	1,25mm <sup>2</sup> to 2,0mm <sup>2</sup> up to 100m
Remote Controller Wiring*	A, B	0,5mm <sup>2</sup> to 2,0mm <sup>2</sup> up to 500m (Wireless Remote Controller up to 400m). Group Control wiring is up to 200m

\* 2 core, no polarity, shielded  
 Note: Power Wiring should comply with Local, National and International Regulation.

Symbol Legend	
Control	
Power	
Remote Control	
Signal	
Piping*	

\*Note: Pipe diameters in mm

**Sistema 2**  
 Floor: PIANO TER Elevation: 0,00m

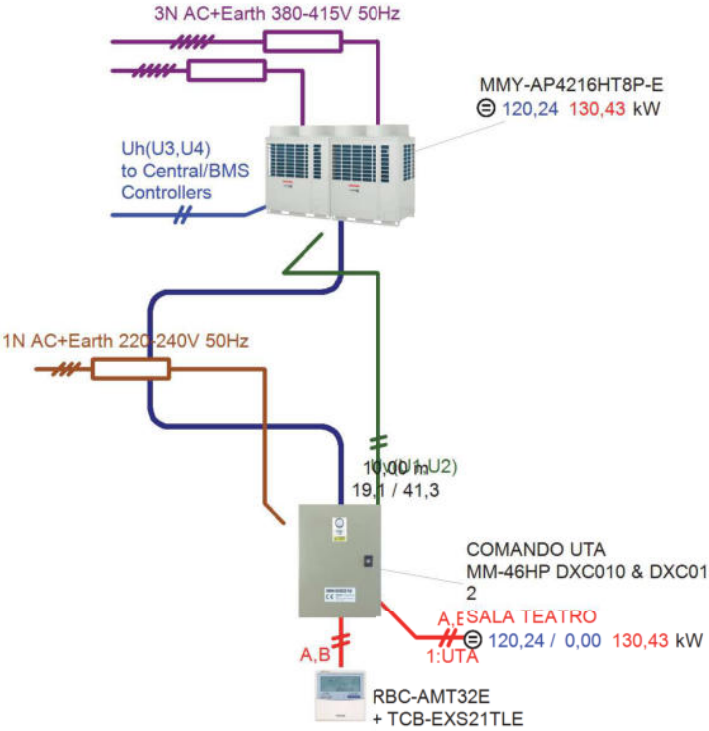

# Control Wiring Diagram

## Sistema 2

Floor: PIANO TER | Elevation: 0,00m

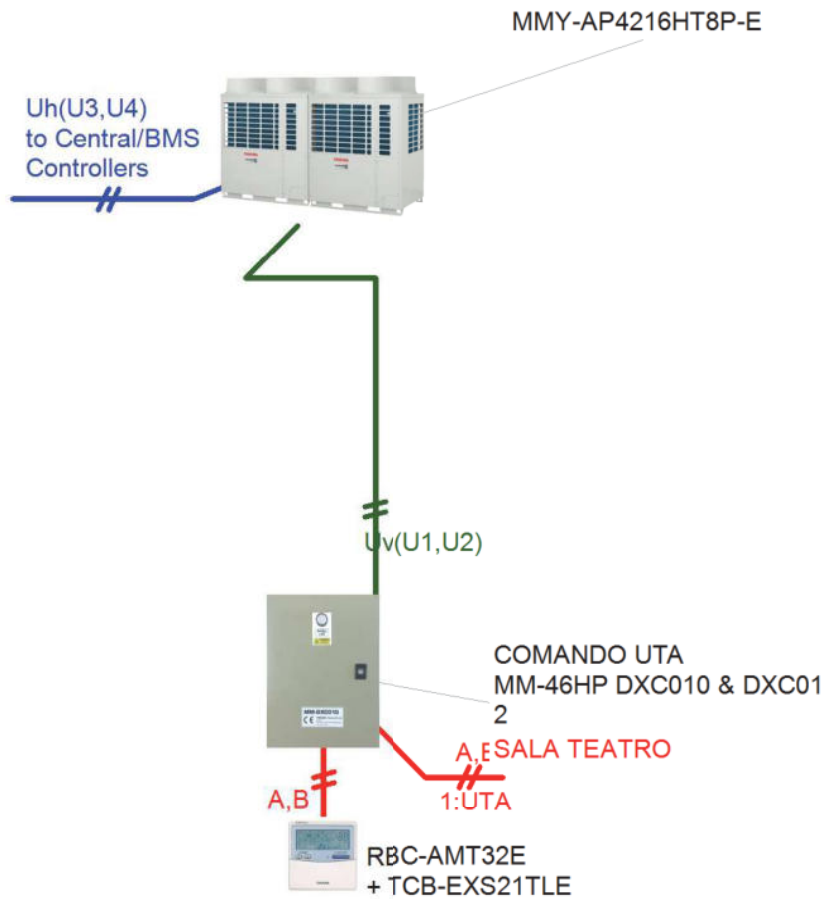

Sistema 2

Floor: PIANO TER Elevation: 0,00m



MMY-AP4216HT8P-E

1N AC+Earth 220-240V 50Hz

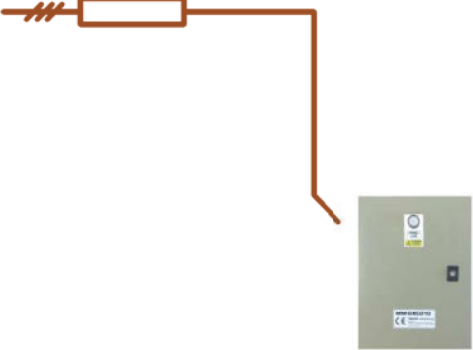

COMANDO UTA  
MM-46HP DXC010 & DXC01  
2  
SALA TEATRO



# Part Load Table

MMY-AP4216HT8P-E (42HP, 117,50kW system)

Cooling		Compressor + Outdoor Fan Power consumption (kW)															
Outdoor Unit (°C)		100%		90%		80%		70%		60%		50%		40%		30%	
Outdoor Unit 100% Capacity (kW)		TC	PI	TC	PI	TC	PI	TC	PI	TC	PI	TC	PI	TC	PI	TC	PI
		(kW)	(kW)	(kW)	(kW)	(kW)	(kW)	(kW)	(kW)	(kW)	(kW)	(kW)	(kW)	(kW)	(kW)	(kW)	(kW)
40,0 °C	109	109	43,8	98,4	34,8	87,5	27,2	76,5	21,0	65,6	16,0	54,7	11,8	43,7	8,49	32,8	5,71
39,0 °C	111	111	43,1	100,0	34,2	88,9	26,8	77,8	20,7	66,7	15,7	55,6	11,7	44,4	8,36	33,3	5,63
37,0 °C	114	114	41,8	103	33,2	91,5	26,0	80,1	20,1	68,7	15,3	57,2	11,3	45,8	8,11	34,3	5,45
35,0 °C	117	117	40,5	106	32,2	94,0	25,2	82,2	19,5	70,5	14,8	58,7	11,0	47,0	7,85	35,2	5,28
33,0 °C	118	118	37,1	106	29,6	94,0	23,3	82,2	18,0	70,5	13,7	58,8	10,2	47,0	7,34	35,2	4,95
31,0 °C	118	118	34,2	106	27,3	94,0	21,5	82,2	16,7	70,5	12,8	58,8	9,54	47,0	6,88	35,2	4,64
30,0 °C	118	118	32,9	106	26,3	94,0	20,7	82,2	16,1	70,5	12,4	58,8	9,23	47,0	6,66	35,2	4,50
29,0 °C	118	118	31,6	106	25,3	94,0	20,0	82,2	15,6	70,5	11,9	58,8	8,94	47,0	6,45	35,2	4,36
27,0 °C	118	118	29,3	106	23,5	94,0	18,6	82,2	14,5	70,5	11,2	58,8	8,38	47,0	6,06	35,2	4,11
25,0 °C	118	118	27,3	106	21,9	94,0	17,4	82,2	13,6	70,5	10,5	58,8	7,86	47,0	5,70	35,2	3,86
23,0 °C	118	118	25,9	106	20,9	94,0	16,6	82,2	13,0	70,5	10,0	58,8	7,54	47,0	5,47	35,2	3,71
21,0 °C	118	118	25,3	106	20,4	94,0	16,2	82,2	12,7	70,5	9,82	58,8	7,41	47,0	5,39	35,2	3,66
20,0 °C	118	118	25,0	106	20,1	94,0	16,0	82,2	12,6	70,5	9,74	58,8	7,35	47,0	5,35	35,2	3,63
19,0 °C	118	118	24,7	106	19,9	94,0	15,9	82,2	12,5	70,5	9,66	58,8	7,30	47,0	5,31	35,2	3,61
17,0 °C	118	118	24,3	106	19,6	94,0	15,6	82,2	12,3	70,5	9,52	58,8	7,20	47,0	5,24	35,2	3,56
15,0 °C	118	118	23,9	106	19,3	94,0	15,4	82,2	12,1	70,5	9,40	58,8	7,11	47,0	5,19	35,2	3,53

TC : Total Capacity      PI : Power Input  
Indoor air temperature conditions : 27,0°C dry-bulb / 19,0°C wet bulb

Heating			Compressor + Outdoor Fan Power consumption (kW)															
Outdoor Unit		Outdoor Unit 100% Heating Capacity (kW)	100% Capacity		90% Capacity		80% Capacity		70% Capacity		60% Capacity		50% Capacity		40% Capacity		30% Capacity	
Dry-Bulb (°C)	Wet-Bulb (°C)		TC	PI	TC	PI	TC	PI	TC	PI	TC	PI	TC	PI	TC	PI	TC	PI
			(kW)	(kW)	(kW)	(kW)	(kW)	(kW)	(kW)	(kW)	(kW)	(kW)	(kW)	(kW)	(kW)	(kW)	(kW)	(kW)
15,0	13,7	127	127	28,4	114	24,0	102	20,1	88,9	16,8	76,2	13,8	63,5	11,1	50,8	8,58	38,1	6,08
13,0	11,8	127	127	29,6	114	24,9	102	20,9	88,9	17,3	76,2	14,3	63,5	11,4	50,8	8,83	38,1	6,27
11,0	9,80	127	127	31,0	114	26,0	102	21,7	88,9	18,0	76,2	14,7	63,5	11,8	50,8	9,10	38,1	6,47
9,00	7,90	127	127	32,5	114	27,1	102	22,5	88,9	18,6	76,2	15,2	63,5	12,2	50,8	9,37	38,1	6,67
7,00	6,00	127	127	34,1	114	28,3	102	23,5	88,9	19,3	76,2	15,7	63,5	12,6	50,8	9,66	38,1	6,89
5,00	4,10	122	122	33,8	110	28,1	98,0	23,3	85,7	19,2	73,5	15,6	61,2	12,5	49,0	9,59	36,7	6,84
3,00	2,20	118	118	33,6	106	27,9	94,3	23,1	82,5	19,0	70,7	15,5	59,0	12,4	47,2	9,51	35,4	6,78
0,00	-0,70	111	111	33,2	99,9	27,6	88,8	22,8	77,7	18,8	66,6	15,3	55,5	12,2	44,4	9,40	33,3	6,70
-3,00	-3,70	104	104	32,8	93,4	27,2	83,0	22,6	72,6	18,6	62,3	15,1	51,9	12,1	41,5	9,29	31,1	6,62
-5,00	-5,60	99,2	99,2	32,5	89,3	27,0	79,4	22,4	69,5	18,4	59,5	15,0	49,6	12,0	39,7	9,21	29,8	6,57
-7,00	-7,60	94,4	94,4	32,2	85,0	26,8	75,6	22,2	66,1	18,3	56,7	14,9	47,2	11,9	37,8	9,13	28,3	6,51
-10,0	-10,5	87,5	87,5	31,8	78,8	26,5	70,0	21,9	61,3	18,0	52,5	14,7	43,8	11,7	35,0	9,02	26,3	6,43
-14,5	-15,0	76,7	76,7	31,2	69,1	26,0	61,4	21,5	53,7	17,7	46,0	14,4	38,4	11,5	30,7	8,85	23,0	6,31

TC : Total Capacity      PI : Power Input  
Indoor air temperature conditions : 20,0°C dry-bulb

# System Equipment List

## Sistema 3

### Outdoor Units

Model	Quantity	Description
MMY-SAP1206HT8P-E	1	Super Modular Multi System (SMMS-e)

### Indoor Units

Model	Quantity	Description
MMK-AP0057HP-E	18	0,6HP High Wall Compact

### Y Joints

Model	Quantity	Description
RBM-BY55E	15	Y-Joint
RBM-BY105E	2	Y-Joint

### Piping Length

Pipe Diameter	Total Length	Gas Side	Discharge Side	Liquid Side
6,4mm	30,00 m	0,00 m	0,00 m	30,00 m
9,5mm	93,50 m	30,00 m	0,00 m	63,50 m
12,7mm	74,50 m	50,00 m	0,00 m	24,50 m
15,9mm	13,50 m	13,50 m	0,00 m	0,00 m
22,2mm	9,50 m	9,50 m	0,00 m	0,00 m
28,6mm	15,00 m	15,00 m	0,00 m	0,00 m

### Total Refrigerant Charge Amount

Refrigerant (R410A)	Amount	Description
Outdoor Unit	5,700 kg	Refrigerant amount charged in factory
Additional Refrigerant	11,215 kg	Amount needed for the pipes at the site
<b>TOTAL:</b>	<b>16,915 kg</b>	

### Outdoor Design Temperature

Mode	Description	Temperature
Cooling	Dry Bulb temperature	35,0 °C
Heating	Wet Bulb temperature	6,0 °C

### Electronic Information(OutdoorUnits)

Property	Value	Description
MOCP(A)	32	Maximum Overcurrent Protection
MCA(A)	26,1	Minimum Circuit Amps
Protection Device Size(A)		Follow applicable local standard as needed
Wire(cable size)(mm <sup>2</sup> ) or AWG(#)		Follow applicable local standard as needed

### Electronic Information(IndoorUnits)

Property	Value	Description
Total MCA(A)	3,6	
Protection Device Size(A)		Follow applicable local standard as needed
Wire(cable size)(mm <sup>2</sup> ) or AWG(#)		Follow applicable local standard as needed

# System Details

## Sistema 3

### Outdoor Unit

Model Name	Cooling (kW)		Heating (kW)		Diversity	
	Rated	Corrected	Rated	Corrected	System	Building
MMY-SAP1206HT8P-E	33,50	31,43	37,50	36,32	90%	0%

### Outdoor Unit Combination

Header	Follower1	Follower2	Follower3	Follower4
MMY-SAP1206HT8P-E				

### Indoor Units

Model Name	UnitName &Room	Capacity Code	Fan Speed Air flow (m³/h)	Mode	Capacity (Total/Sensible) [kW]		
					Rated	Corrected	Required
MMK-AP0057HP-E	CAM 1 SN CAM 1 SN P3	0,6	Medium 370	Cooling	1,70/1,50	1,51/1,23	0,70/0,50
				Heating	1,90	1,69	1,00
MMK-AP0057HP-E	CAM 1 DX CAM 1 DX P3	0,6	Medium 370	Cooling	1,70/1,50	1,49/1,21	0,70/0,50
				Heating	1,90	1,68	1,00
MMK-AP0057HP-E	CAM 1 SN CAM 1 SN P2	0,6	Medium 370	Cooling	1,70/1,50	1,49/1,21	0,70/0,50
				Heating	1,90	1,68	1,00
MMK-AP0057HP-E	CAM 1 DX CAM 1 DX P2	0,6	Medium 370	Cooling	1,70/1,50	1,49/1,20	0,70/0,50
				Heating	1,90	1,68	1,00
MMK-AP0057HP-E	CAM 3 SN P1 CAM 3 SN P1	0,6	Medium 370	Cooling	1,70/1,50	1,46/1,18	0,70/0,50
				Heating	1,90	1,66	1,00
MMK-AP0057HP-E	CAM 3 DX CAM 3 DX P1	0,6	Medium 370	Cooling	1,70/1,50	1,44/1,16	0,70/0,50
				Heating	1,90	1,66	1,00
MMK-AP0057HP-E	CAM 2 SN P1 CAM 2 SN P1	0,6	Medium 370	Cooling	1,70/1,50	1,46/1,18	0,70/0,50
				Heating	1,90	1,67	1,00
MMK-AP0057HP-E	CAM 2 DX CAM 2 DX P1	0,6	Medium 370	Cooling	1,70/1,50	1,44/1,17	0,70/0,50
				Heating	1,90	1,66	1,00
MMK-AP0057HP-E	CAM 1 SN P1 CAM 1 SN P1	0,6	Medium 370	Cooling	1,70/1,50	1,47/1,19	0,70/0,50
				Heating	1,90	1,67	1,00
MMK-AP0057HP-E	CAM 1 DX CAM 1 DX P1	0,6	Medium 370	Cooling	1,70/1,50	1,45/1,17	0,70/0,50
				Heating	1,90	1,66	1,00
MMK-AP0057HP-E	CAM 3 SN CAM 3 SN P3	0,6	Medium 370	Cooling	1,70/1,50	1,50/1,21	0,70/0,50
				Heating	1,90	1,69	1,00
MMK-AP0057HP-E	CAM 3 DX CAM 3 DX P3	0,6	Medium 370	Cooling	1,70/1,50	1,48/1,20	0,70/0,50
				Heating	1,90	1,68	1,00
MMK-AP0057HP-E	CAM 3 SN CAM 3 SN P2	0,6	Medium 370	Cooling	1,70/1,50	1,48/1,20	0,70/0,50
				Heating	1,90	1,68	1,00
MMK-AP0057HP-E	CAM 3 DX CAM 3 DX P2	0,6	Medium 370	Cooling	1,70/1,50	1,47/1,19	0,70/0,50
				Heating	1,90	1,67	1,00
MMK-AP0057HP-E	CAM 2 SN CAM 2 SN P3	0,6	Medium 370	Cooling	1,70/1,50	1,51/1,22	0,70/0,50
				Heating	1,90	1,69	1,00
MMK-AP0057HP-E	CAM 2 DX CAM 2 DX P3	0,6	Medium 370	Cooling	1,70/1,50	1,49/1,20	0,70/0,50
				Heating	1,90	1,68	1,00
MMK-AP0057HP-E	CAM 2 SN CAM 2 SN P2	0,6	Medium 370	Cooling	1,70/1,50	1,49/1,20	0,70/0,50
				Heating	1,90	1,68	1,00
MMK-AP0057HP-E	CAM 2 DX CAM 2 DX P2	0,6	Medium 370	Cooling	1,70/1,50	1,48/1,20	0,70/0,50
				Heating	1,90	1,68	1,00

## System Details

### Floor Information

Floors	Room Name	Name	Indoor Units		Design Conditions		
			Model	Mode	DB[°C]	WB[°C]	RH[%]
PIANO 3	CAM 1 SN P3	CAM 1 SN	MMK-AP0057HP-E	Cooling	27,0	19,6	50,00
				Heating	20,0		
	CAM 2 SN P3	CAM 2 SN	MMK-AP0057HP-E	Cooling	27,0	19,6	50,00
				Heating	20,0		
	CAM 3 SN P3	CAM 3 SN	MMK-AP0057HP-E	Cooling	27,0	19,6	50,00
				Heating	20,0		
	CAM 1 DX P3	CAM 1 DX	MMK-AP0057HP-E	Cooling	27,0	19,6	50,00
				Heating	20,0		
	CAM 2 DX P3	CAM 2 DX	MMK-AP0057HP-E	Cooling	27,0	19,6	50,00
				Heating	20,0		
	CAM 3 DX P3	CAM 3 DX	MMK-AP0057HP-E	Cooling	27,0	19,6	50,00
				Heating	20,0		
PIANO 2	CAM 1 SN P2	CAM 1 SN	MMK-AP0057HP-E	Cooling	27,0	19,6	50,00
				Heating	20,0		
	CAM 2 SN P2	CAM 2 SN	MMK-AP0057HP-E	Cooling	27,0	19,6	50,00
				Heating	20,0		
	CAM 3 SN P2	CAM 3 SN	MMK-AP0057HP-E	Cooling	27,0	19,6	50,00
				Heating	20,0		
	CAM 1 DX P2	CAM 1 DX	MMK-AP0057HP-E	Cooling	27,0	19,6	50,00
				Heating	20,0		
	CAM 2 DX P2	CAM 2 DX	MMK-AP0057HP-E	Cooling	27,0	19,6	50,00
				Heating	20,0		
	CAM 3 DX P2	CAM 3 DX	MMK-AP0057HP-E	Cooling	27,0	19,6	50,00
				Heating	20,0		
PIANO 1	CAM 1 SN P1	CAM 1 SN P1	MMK-AP0057HP-E	Cooling	27,0	19,6	50,00
				Heating	20,0		
	CAM 2 SN P1	CAM 2 SN P1	MMK-AP0057HP-E	Cooling	27,0	19,6	50,00
				Heating	20,0		
	CAM 3 SN P1	CAM 3 SN P1	MMK-AP0057HP-E	Cooling	27,0	19,6	50,00
				Heating	20,0		
	CAM 1 DX P1	CAM 1 DX	MMK-AP0057HP-E	Cooling	27,0	19,6	50,00
				Heating	20,0		
	CAM 2 DX P1	CAM 2 DX	MMK-AP0057HP-E	Cooling	27,0	19,6	50,00
				Heating	20,0		
	CAM 3 DX P1	CAM 3 DX	MMK-AP0057HP-E	Cooling	27,0	19,6	50,00
				Heating	20,0		

# Seasonal Power Consumption

System Name Sistema 3

Average Daily Temperature

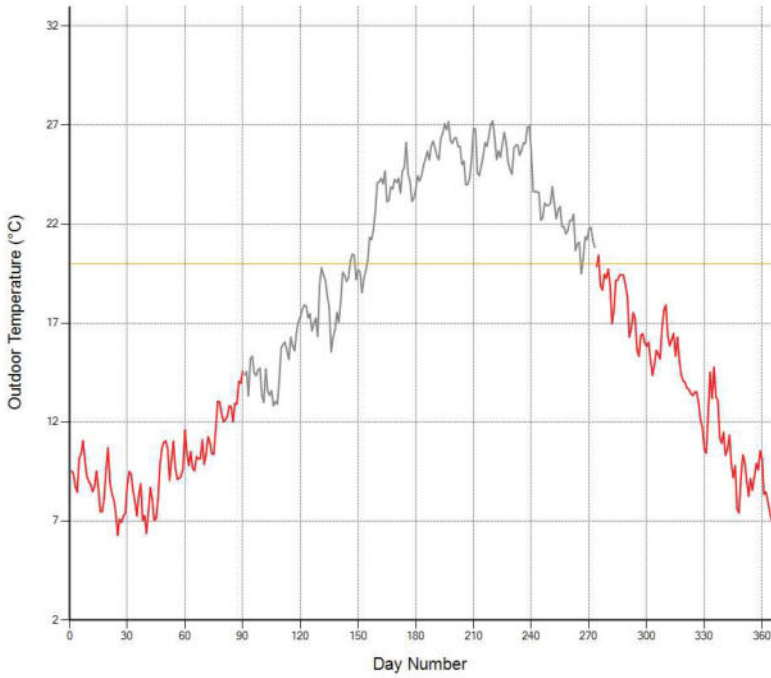

— Outside Temperature (Heating Period)   
 — Outside Temperature (Cooling Period)   
 — Outside Temperature   
 — Thermo Off Cooling  
— Thermo Off Heating

Yearly Outdoor Temperature Condition

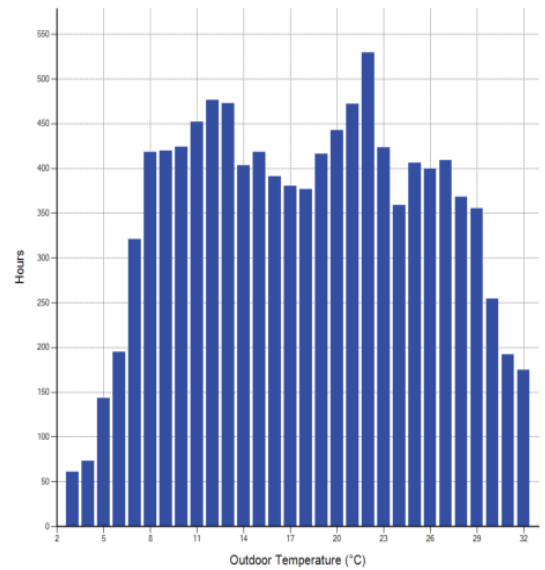

Capacity Trend

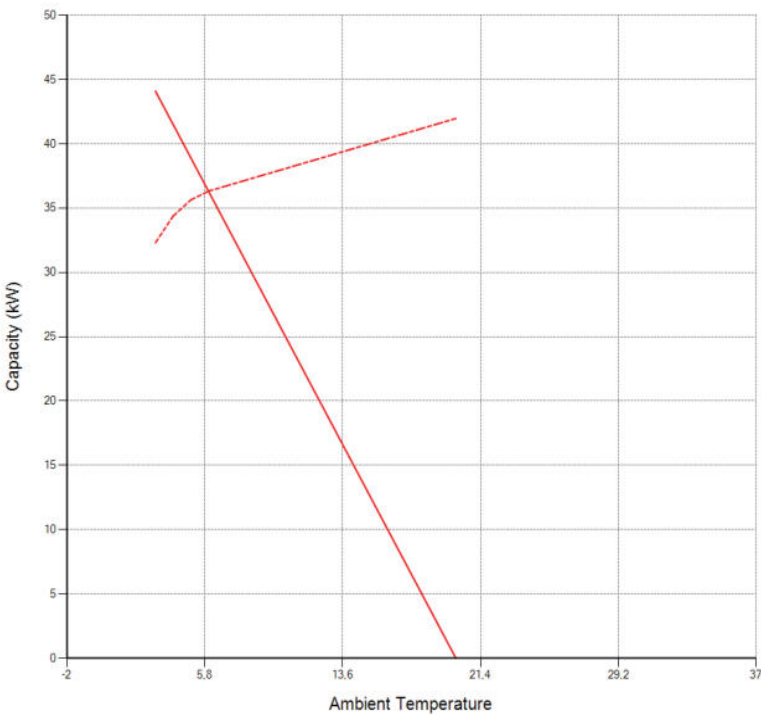

- - - System Capacity Heating   
 — Building Load Heating

# Schematic Overview

System information	
Indoor Units	18 of 27
Capacity Ratio	90,0%
Total Pipe Length	107,00 m
Indoor Cap. Tot./Sen.	26,59 kW/21,52 kW
Indoor Cap. Heat.	30,16 kW
Building diversity	0%

Outdoor/Indoor Legend	
Unit Name	
Model Name	
Room Name	
⊖ Corrected capacity	Tot./Sens./ Heat.

Piping Legend	
Actual Length	
Liquid / Suction Gas diameters	
Note: It is the responsibility of the consultant or contractor, to verify and confirm that the equipment selection and system design is correct before installation.	

Branches Legend		
a	RBM-BY55E	(x15)
b	RBM-BY105E	(x2)

## Sistema 3

Floor: PIANO TERRAZZA Elevation: 0,00m



# Schematic Overview

System information	
Indoor Units	18 of 27
Capacity Ratio	90,0%
Total Pipe Length	107,00 m
Indoor Cap. Tot./Sen.	26,59 kW/21,52 kW
Indoor Cap. Heat.	30,16 kW
Building diversity	0%

Outdoor/Indoor Legend	
Unit Name	
Model Name	
Room Name	
⊖ Corrected capacity	Tot./Sens./ Heat.

Piping Legend	
Actual Length	
Liquid / Suction Gas diameters	
Note: It is the responsibility of the consultant or contractor, to verify and confirm that the equipment selection and system design is correct before installation.	

Branches Legend		
a	RBM-BY55E	(x15)
b	RBM-BY105E	(x2)

## Sistema 3

Floor: PIANO 3

Elevation: Above Outdoor Unit -5,00m

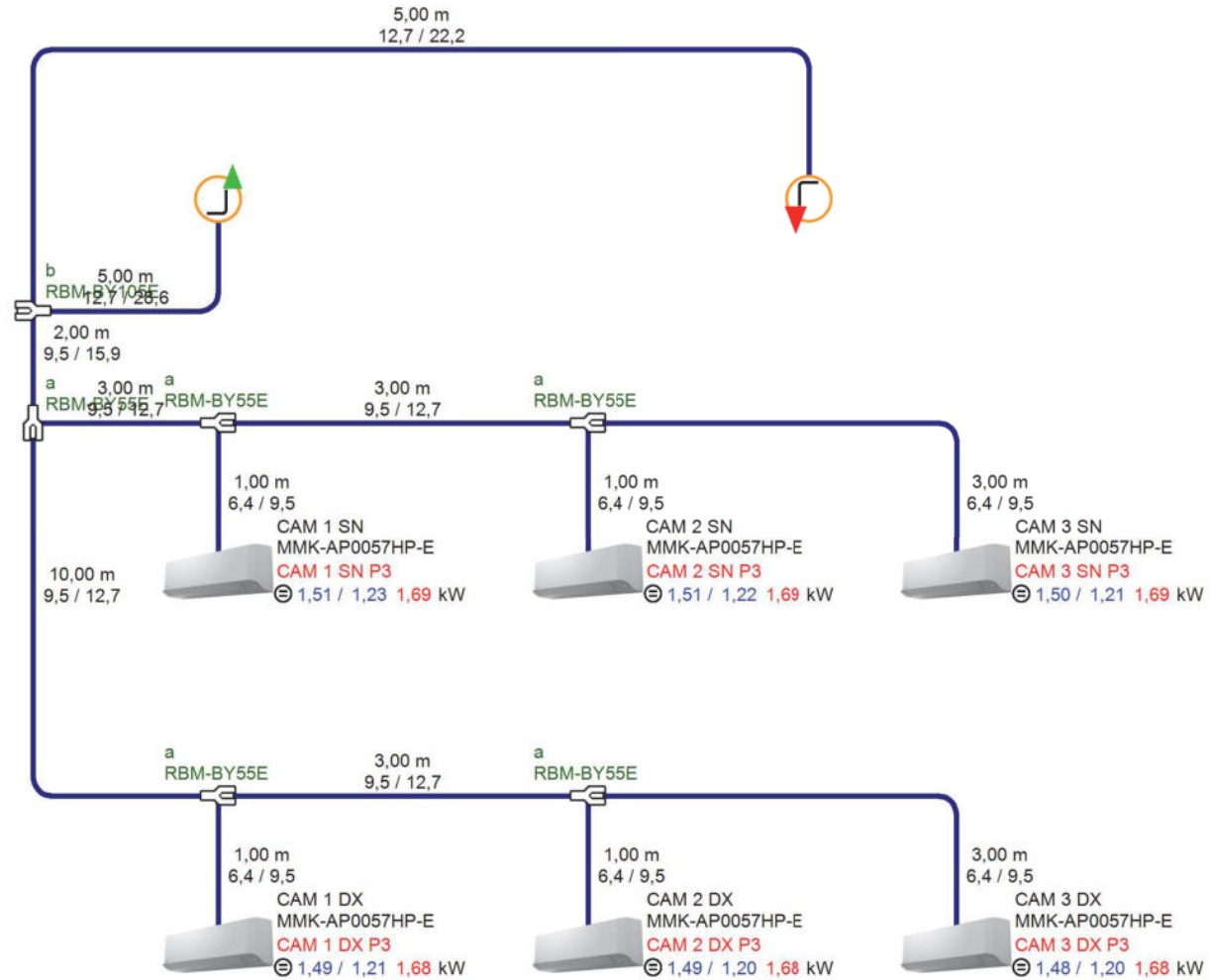

# Schematic Overview

System information	
Indoor Units	18 of 27
Capacity Ratio	90,0%
Total Pipe Length	107,00 m
Indoor Cap. Tot./Sen.	26,59 kW/21,52 kW
Indoor Cap. Heat.	30,16 kW
Building diversity	0%

Outdoor/Indoor Legend	
Unit Name	
Model Name	
Room Name	
⊖ Corrected capacity	Tot./Sens./ Heat.

Piping Legend	
Actual Length	
Liquid / Suction Gas diameters	
Note: It is the responsibility of the consultant or contractor, to verify and confirm that the equipment selection and system design is correct before installation.	

Branches Legend		
a	RBM-BY55E	(x15)
b	RBM-BY105E	(x2)

## Sistema 3

Floor: PIANO 2

Elevation: Above Outdoor Unit -7,50m

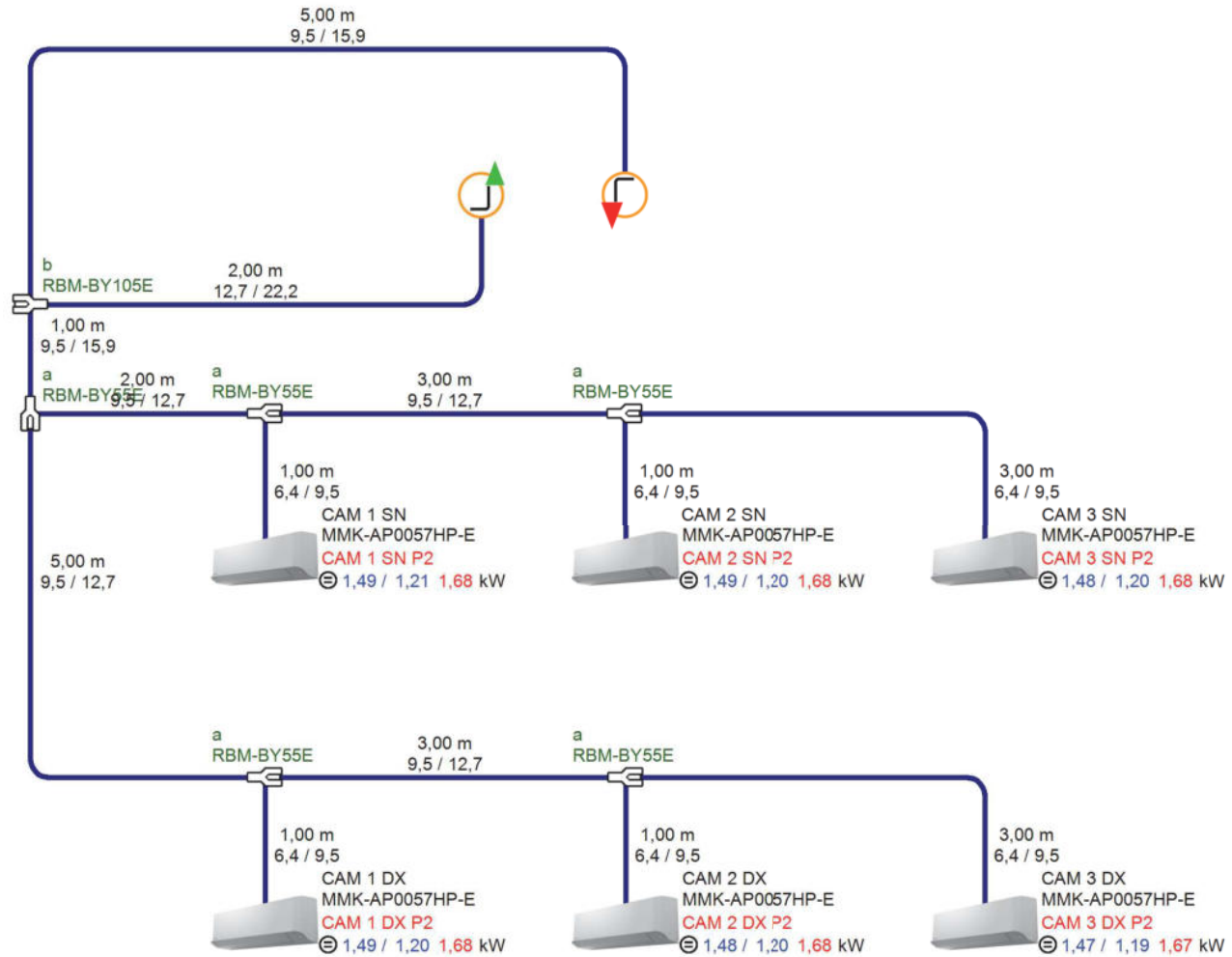



# Schematic Overview

System information	
Indoor Units	18 of 27
Capacity Ratio	90,0%
Total Pipe Length	107,00 m
Indoor Cap. Tot./Sen.	26,59 kW/21,52 kW
Indoor Cap. Heat.	30,16 kW
Building diversity	0%

Outdoor/Indoor Legend	
Unit Name	
Model Name	
Room Name	
⊖ Corrected capacity	⊖ Tot./Sens./ Heat.

Piping Legend	
Actual Length	
Liquid / Suction Gas diameters	
Note: It is the responsibility of the consultant or contractor, to verify and confirm that the equipment selection and system design is correct before installation.	

Branches Legend		
a	RBM-BY55E	(x15)
b	RBM-BY105E	(x2)

## Sistema 3

Floor: PIANO 1

Elevation: Above Outdoor Unit -11,00m

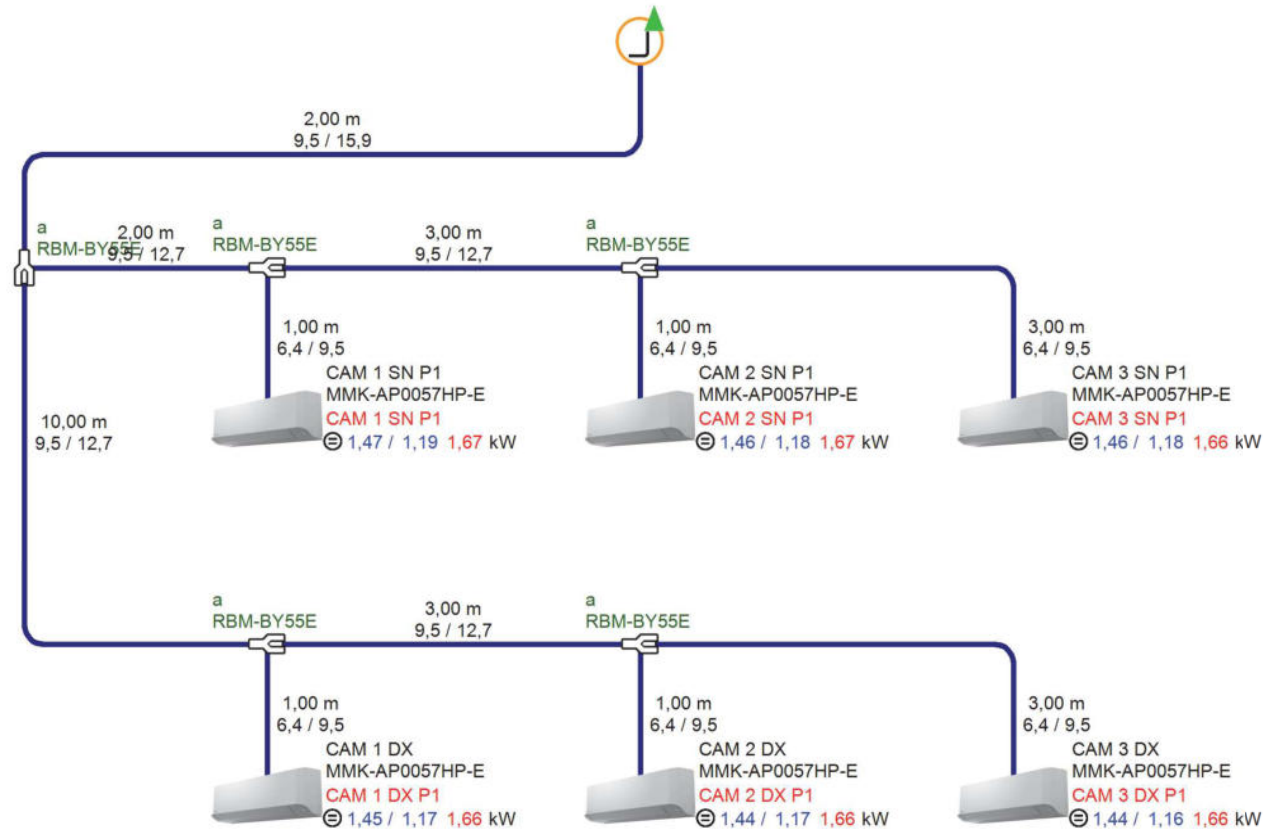

**Sistema 3**

MMY-SAP1206HT8P-E

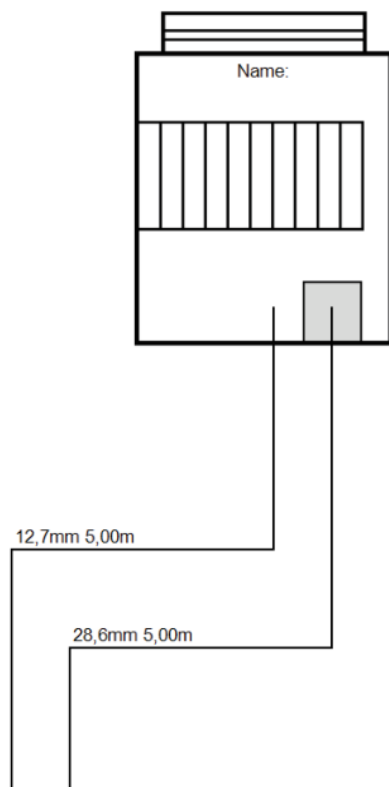

**Accessories**

**Header**

**Follower1**

**Follower2**

**Follower3**

**Follower4**

**Electrical Information**

Summary: 3N AC+Earth 380-415V 50Hz

- Slot 1
- Slot 2
- Slot 3
- Slot 4
- Slot 5

# System Wiring Diagram

## Sistema 3

Floor: PIANO TER | Elevation: 0,00m

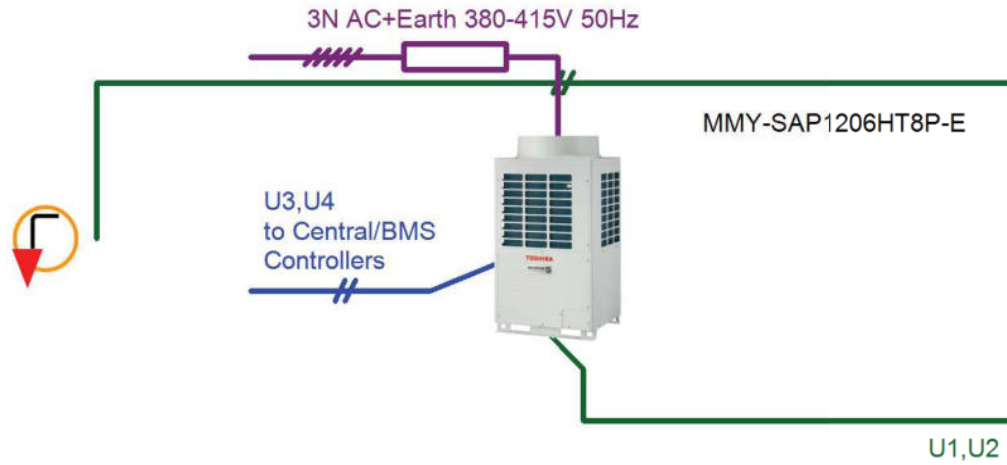

# System Wiring Diagram

## Sistema 3

Floor: PIANO 3 Elevation: Above Outdoor Unit -5,00m

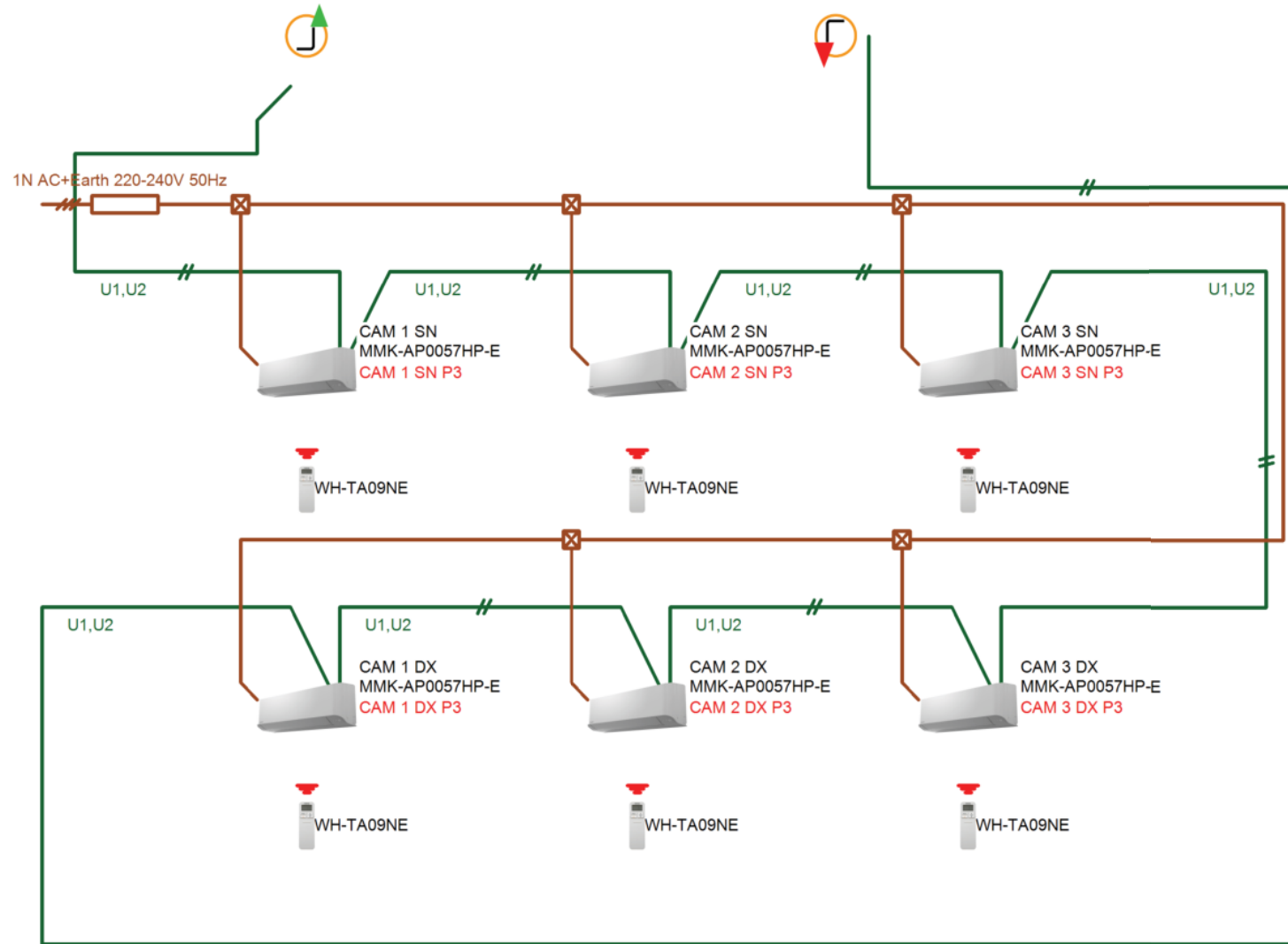

# System Wiring Diagram

## Sistema 3

Floor: PIANO 2 Elevation: Above Outdoor Unit -7,50m

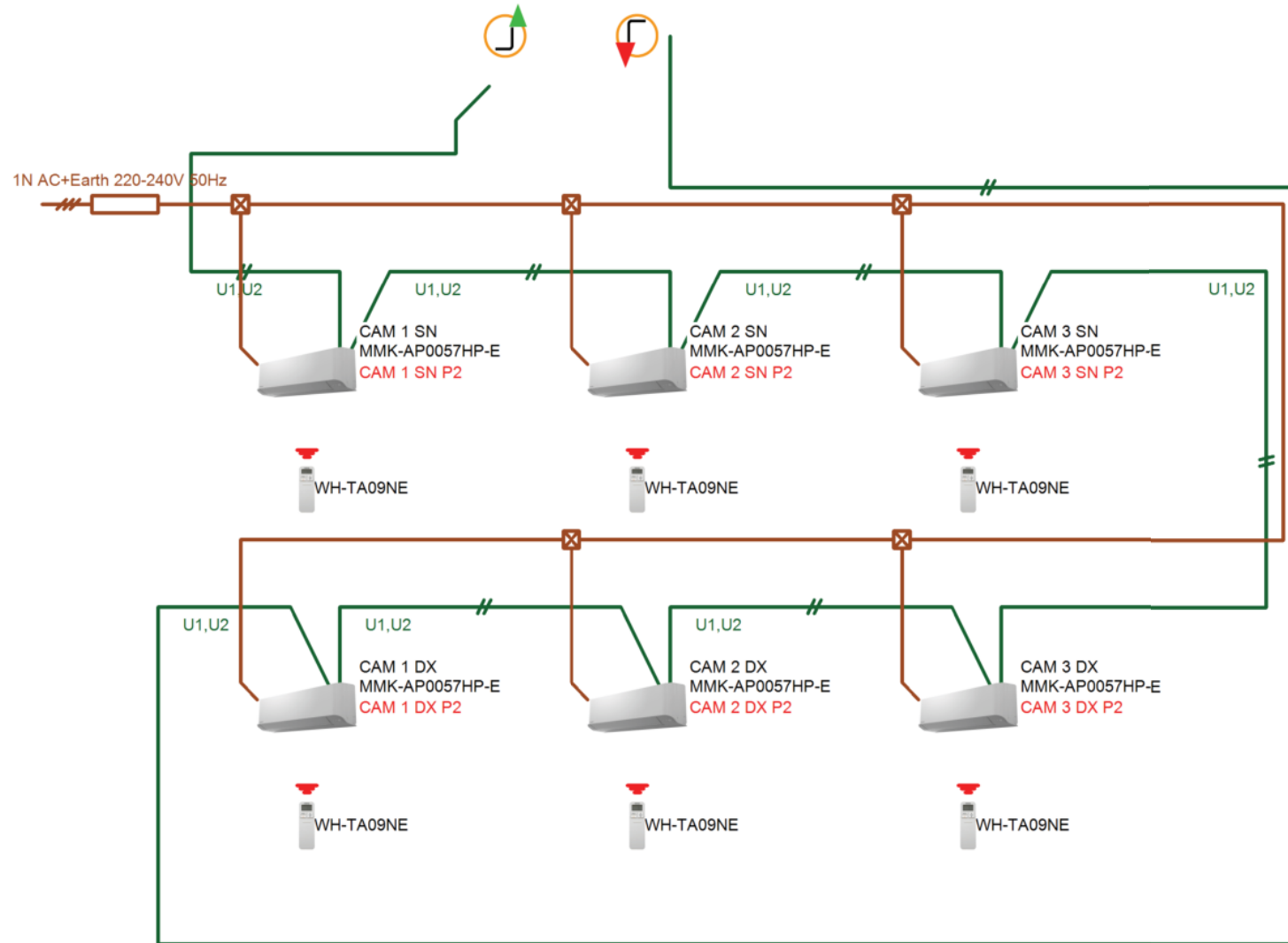

# System Wiring Diagram

## Sistema 3

Floor: PIANO 1 Elevation: Above Outdoor Unit -11,00m

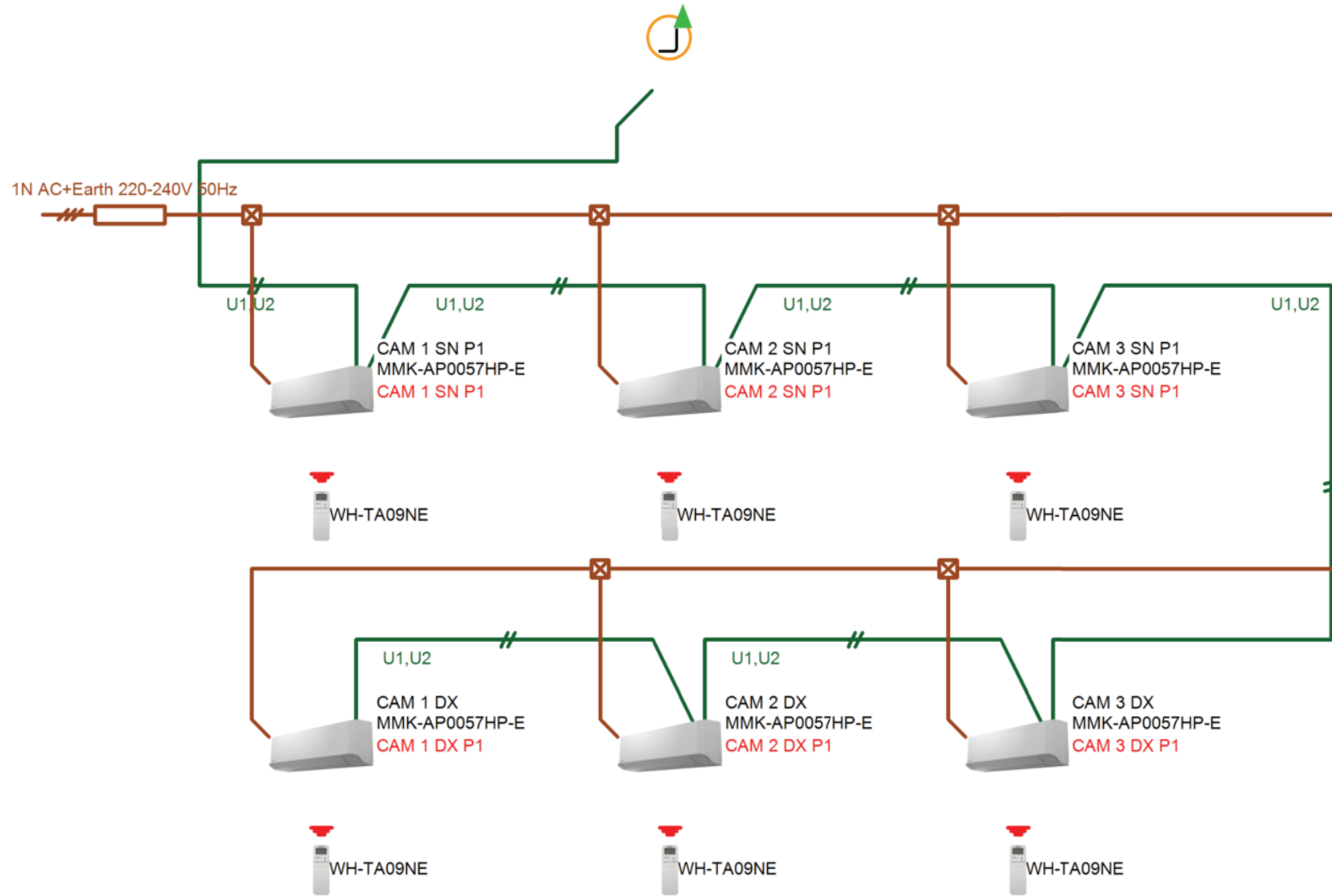

# Piping & Wiring Diagram

Control Wiring Legend	Label	Wiring Size and Length
Outdoor - Indoor Control Wiring*	U1, U2	1,25mm <sup>2</sup> up to 1000m & 2,0mm <sup>2</sup> up to 2000m
Central Control Wiring*	U3, U4	1,25mm <sup>2</sup> up to 1000m & 2,0mm <sup>2</sup> up to 2000m
Outdoor Units Control Wiring*	U5, U6	1,25mm <sup>2</sup> to 2,0mm <sup>2</sup> up to 100m
Remote Controller Wiring*	A, B	0,5mm <sup>2</sup> to 2,0mm <sup>2</sup> up to 500m (Wireless Remote Controller up to 400m). Group Control wiring is up to 200m

\* 2 core, no polarity, shielded  
 Note: Power Wiring should comply with Local, National and International Regulation.

Symbol Legend		
Control		
Power		
Remote Control		
Signal		
Piping*		
*Note: Pipe diameters in mm		
Branches Legend		
RBM-BY55E	a	(x15)
RBM-BY105E	b	(x2)

**Sistema 3**  
 Floor: PIANO TER | Elevation: 0,00m

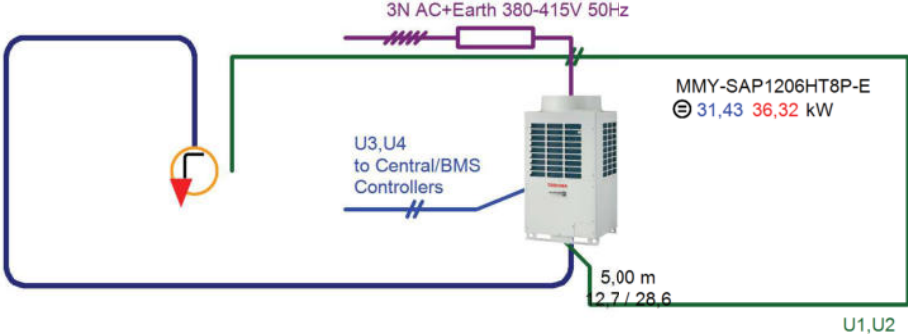

# Piping & Wiring Diagram

Control Wiring Legend	Label	Wiring Size and Length
Outdoor - Indoor Control Wiring*	U1,U2	1,25mm <sup>2</sup> up to 1000m & 2,0mm <sup>2</sup> up to 2000m
Central Control Wiring*	U3,U4	1,25mm <sup>2</sup> up to 1000m & 2,0mm <sup>2</sup> up to 2000m
Outdoor Units Control Wiring*	U5,U6	1,25mm <sup>2</sup> to 2,0mm <sup>2</sup> up to 100m
Remote Controller Wiring*	A,B	0,5mm <sup>2</sup> to 2,0mm <sup>2</sup> up to 500m (Wireless Remote Controller up to 400m). Group Control wiring is up to 200m

\* 2 core, no polarity, shielded  
 Note: Power Wiring should comply with Local, National and International Regulation.

## Sistema 3

Floor: PIANO 3 Elevation: Above Outdoor Unit -5,00m

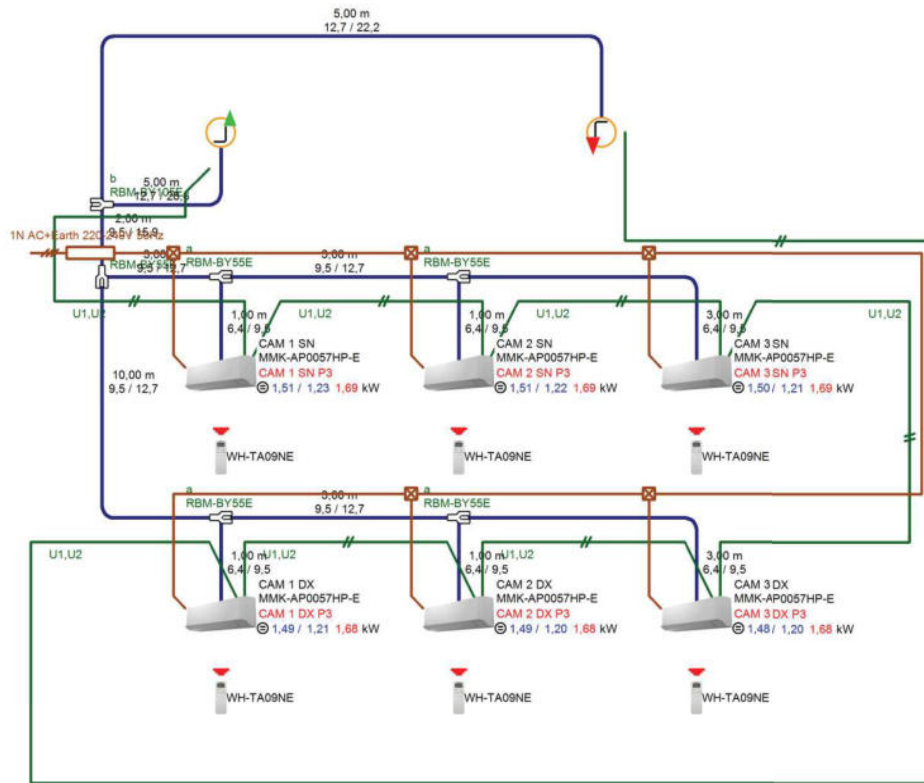



# Piping & Wiring Diagram

Control Wiring Legend	Label	Wiring Size and Length
Outdoor - Indoor Control Wiring*	U1,U2	1,25mm <sup>2</sup> up to 1000m & 2,0mm <sup>2</sup> up to 2000m
Central Control Wiring*	U3,U4	1,25mm <sup>2</sup> up to 1000m & 2,0mm <sup>2</sup> up to 2000m
Outdoor Units Control Wiring*	U5,U6	1,25mm <sup>2</sup> to 2,0mm <sup>2</sup> up to 100m
Remote Controller Wiring*	A,B	0,5mm <sup>2</sup> to 2,0mm <sup>2</sup> up to 500m (Wireless Remote Controller up to 400m). Group Control wiring is up to 200m

\* 2 core, no polarity, shielded  
 Note: Power Wiring should comply with Local, National and International Regulation.

## Sistema 3

Floor: PIANO 2 Elevation: Above Outdoor Unit -7,50m

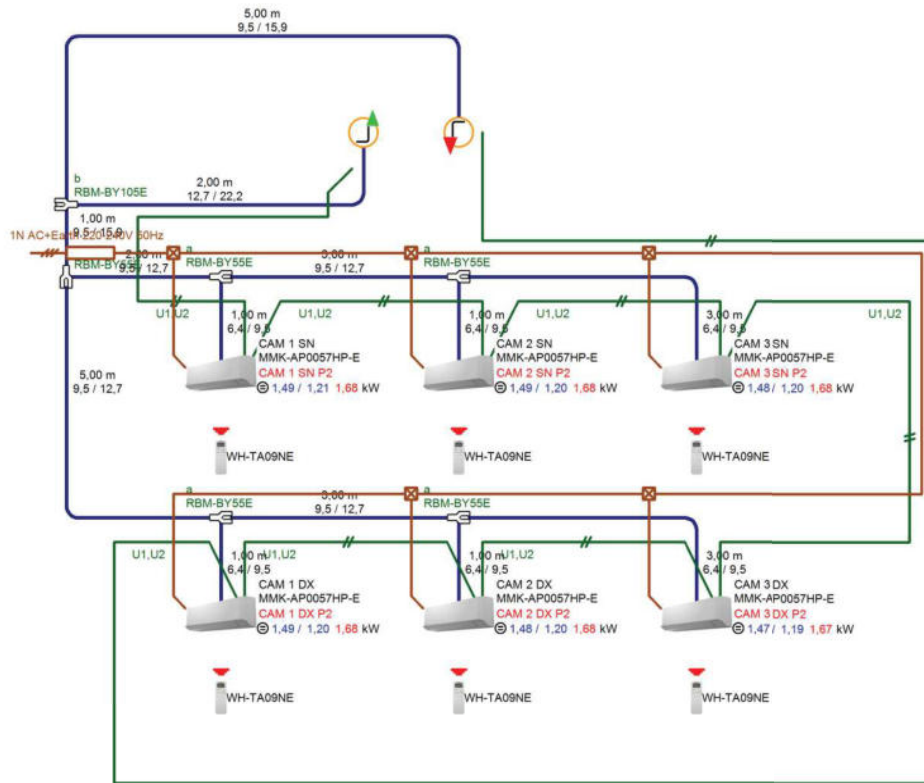

# Piping & Wiring Diagram

Control Wiring Legend	Label	Wiring Size and Length
Outdoor - Indoor Control Wiring*	U1,U2	1,25mm <sup>2</sup> up to 1000m & 2,0mm <sup>2</sup> up to 2000m
Central Control Wiring*	U3,U4	1,25mm <sup>2</sup> up to 1000m & 2,0mm <sup>2</sup> up to 2000m
Outdoor Units Control Wiring*	U5,U6	1,25mm <sup>2</sup> to 2,0mm <sup>2</sup> up to 100m
Remote Controller Wiring*	A,B	0,5mm <sup>2</sup> to 2,0mm <sup>2</sup> up to 500m (Wireless Remote Controller up to 400m). Group Control wiring is up to 200m

\* 2 core, no polarity, shielded  
 Note: Power Wiring should comply with Local, National and International Regulation.

**Sistema 3**  
 Floor: PIANO 1 Elevation: Above Outdoor Unit -11,00m

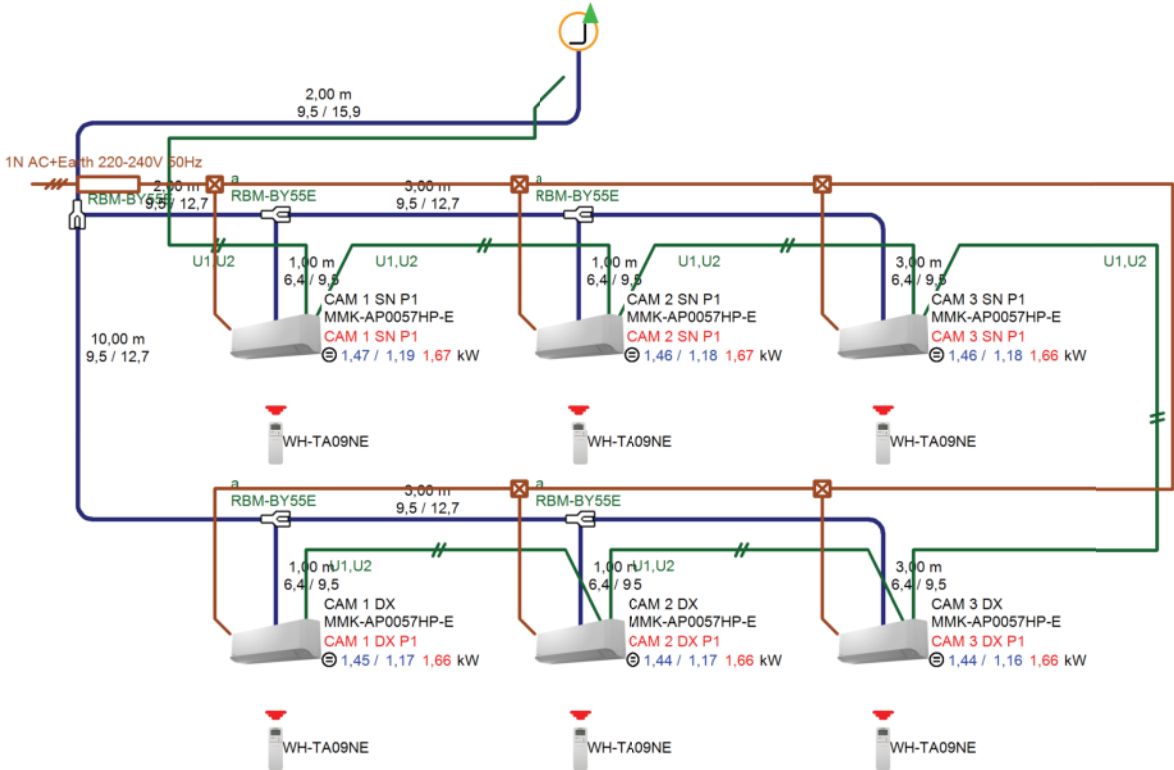

# Control Wiring Diagram

## Sistema 3

Floor: PIANO TER | Elevation: 0,00m

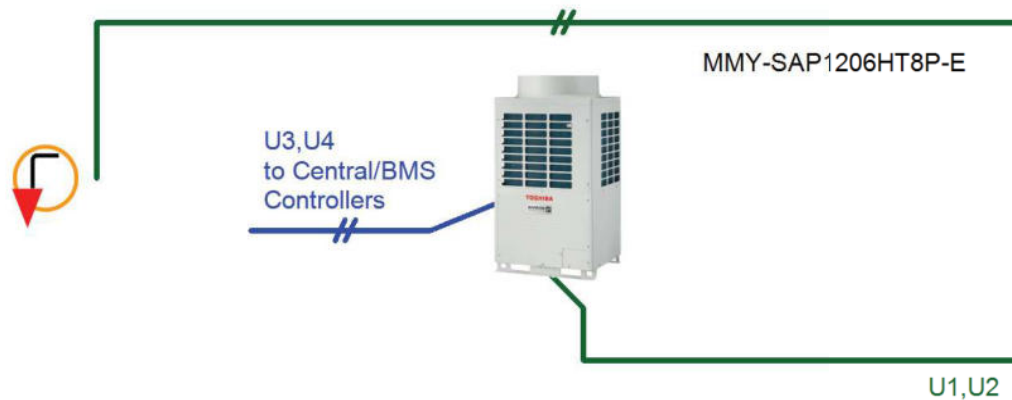

# Control Wiring Diagram

## Sistema 3

Floor: PIANO 3 Elevation: Above Outdoor Unit -5,00m

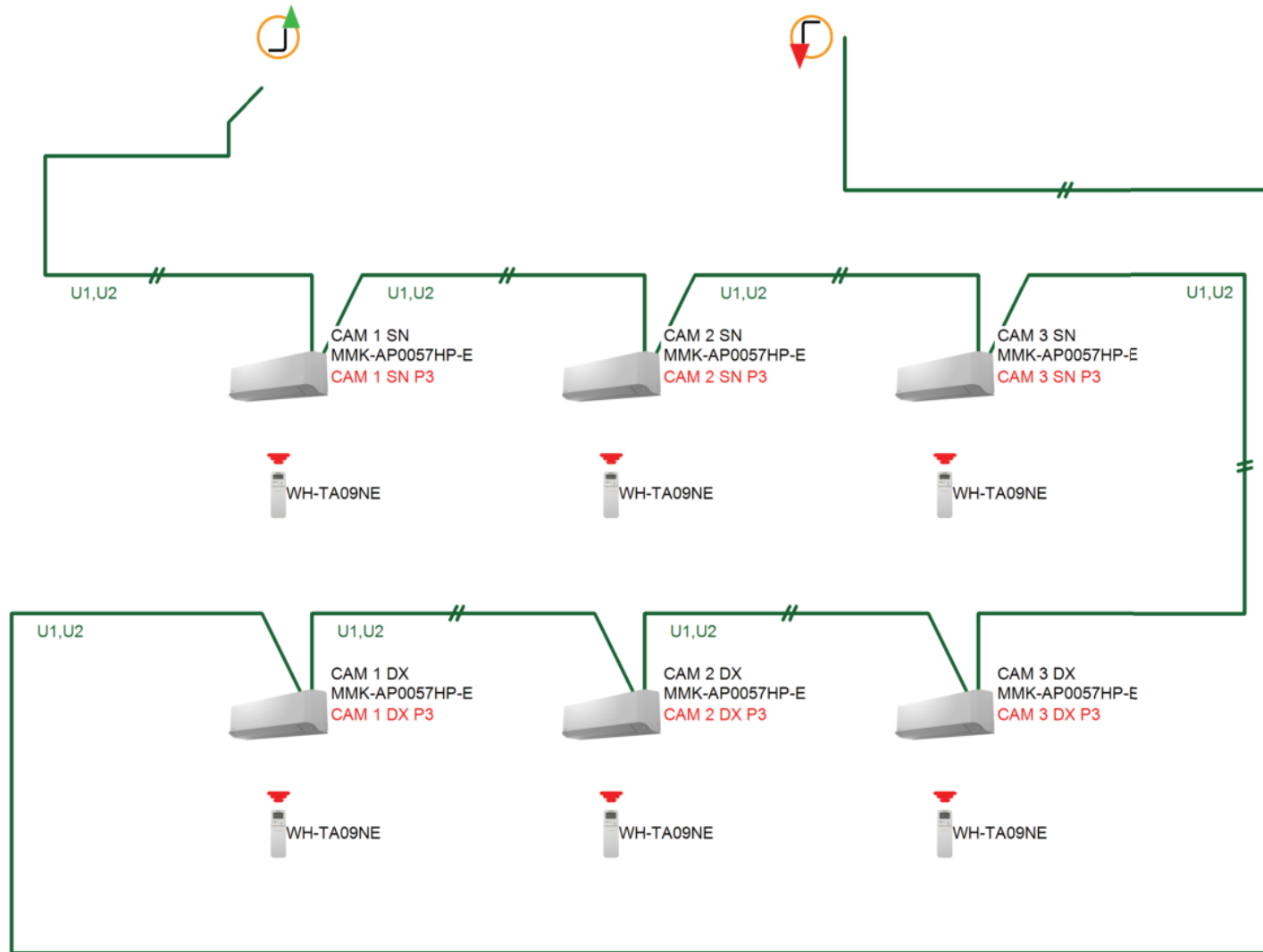

# Control Wiring Diagram

## Sistema 3

Floor: PIANO 2 Elevation: Above Outdoor Unit -7,50m

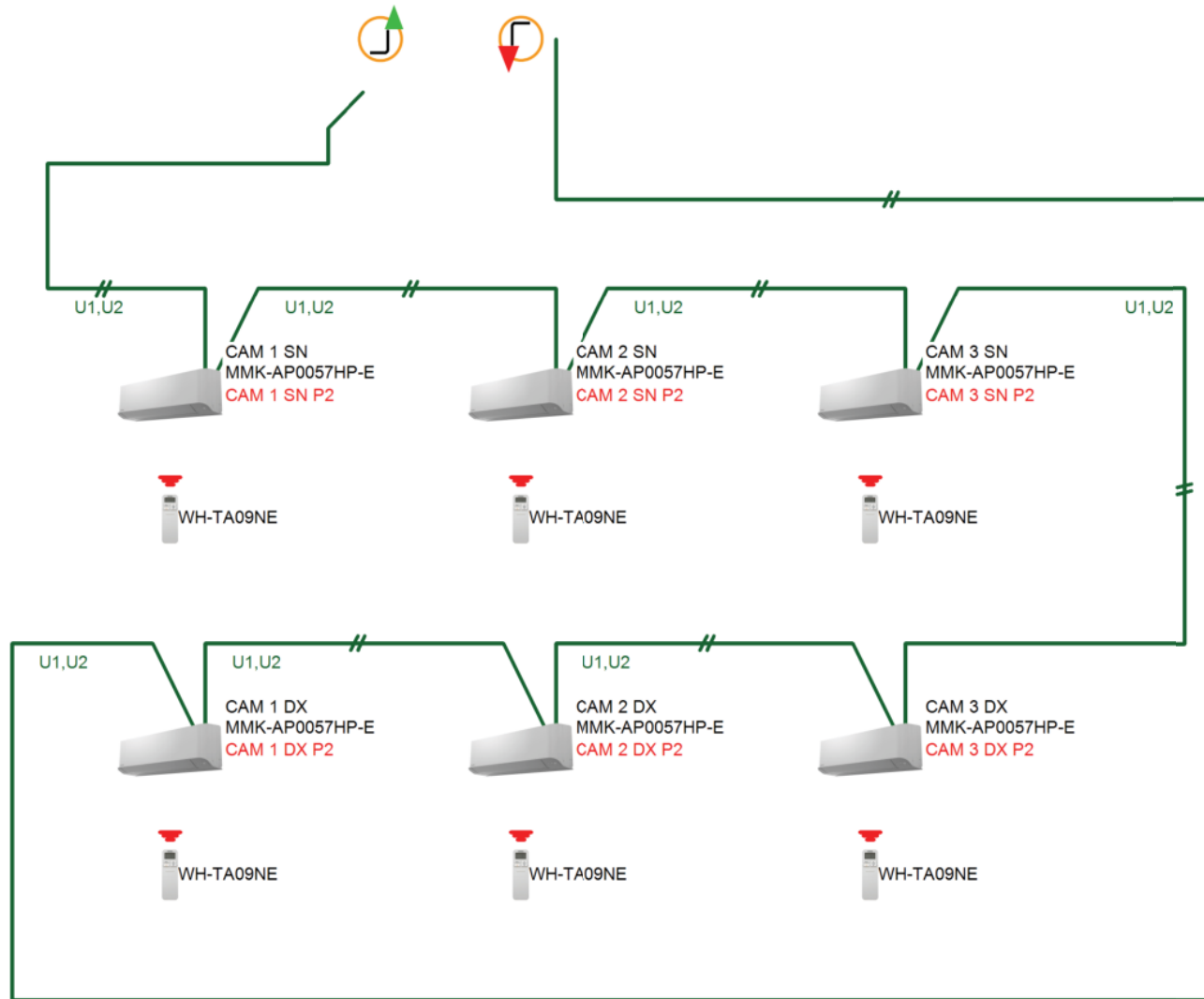

# Control Wiring Diagram

## Sistema 3

Floor: PIANO 1 Elevation: Above Outdoor Unit -11,00m

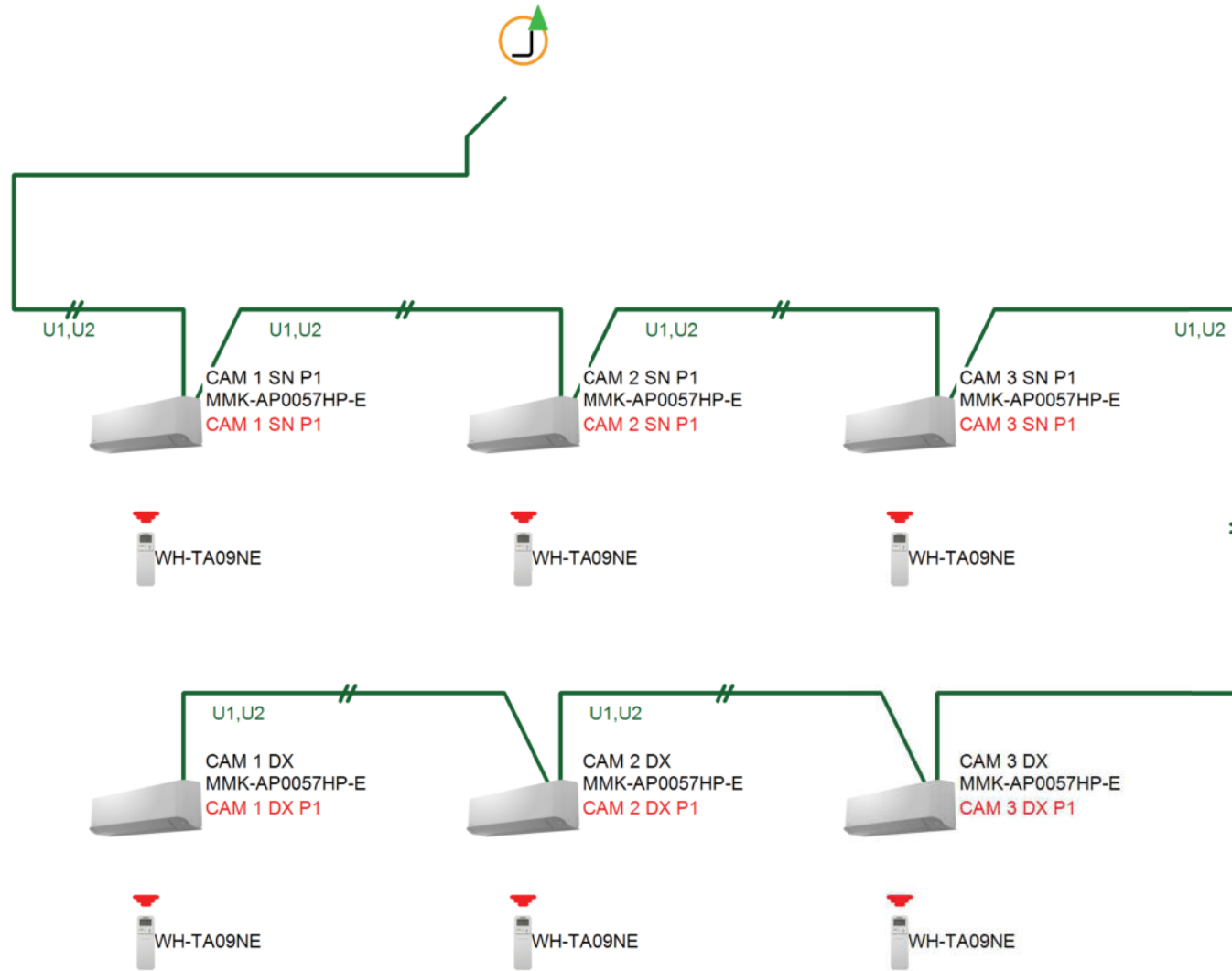

# Power Wiring Diagram

## Sistema 3

Floor: PIANO TER | Elevation: 0,00m



# Power Wiring Diagram

## Sistema 3

Floor: PIANO 3 Elevation: Above Outdoor Unit -5,00m



1N AC+Earth 220-240V 50Hz

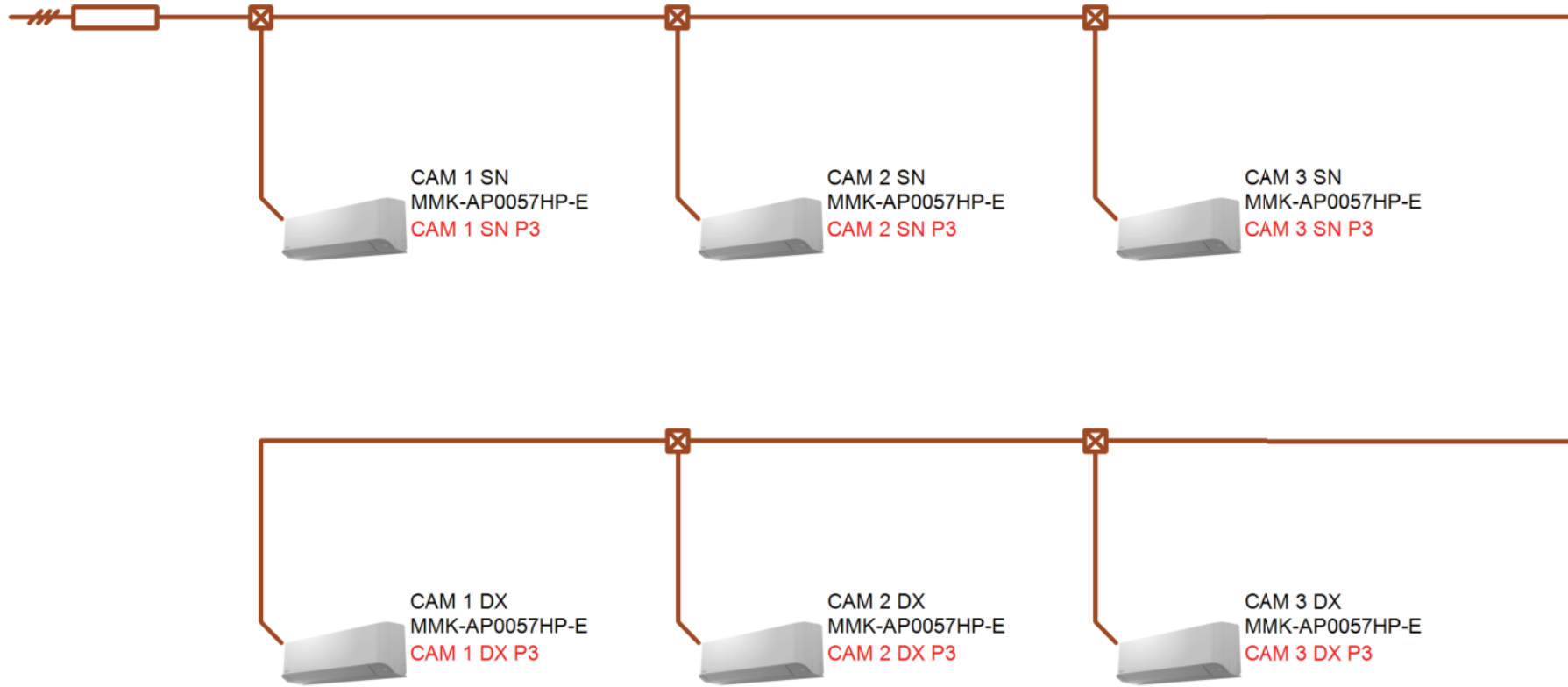



# Power Wiring Diagram

## Sistema 3

Floor: PIANO 2 Elevation: Above Outdoor Unit -7,50m



1N AC+Earth 220-240V 50Hz

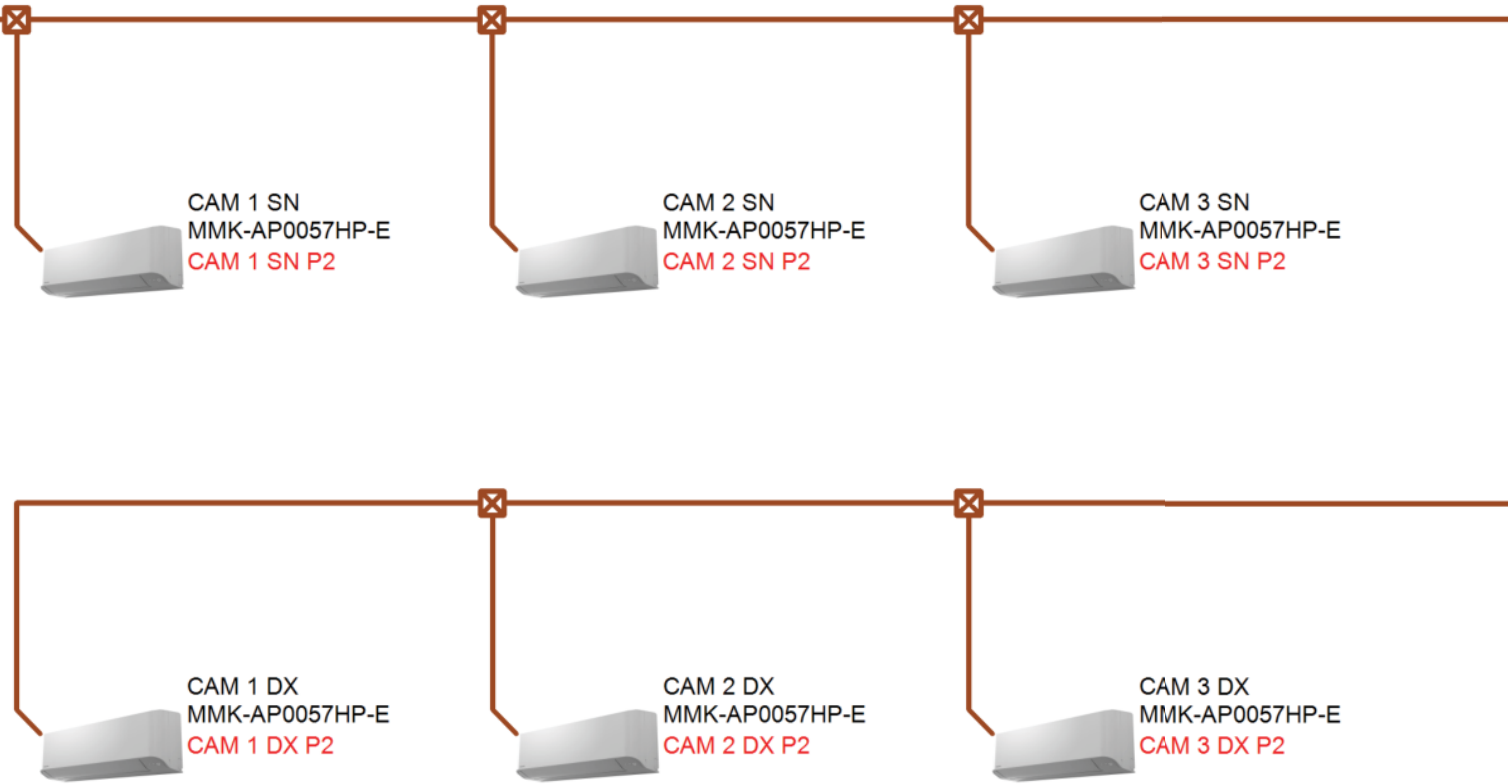

# Power Wiring Diagram

## Sistema 3

Floor: PIANO 1 Elevation: Above Outdoor Unit -11,00m



1N AC+Earth 220-240V 50Hz

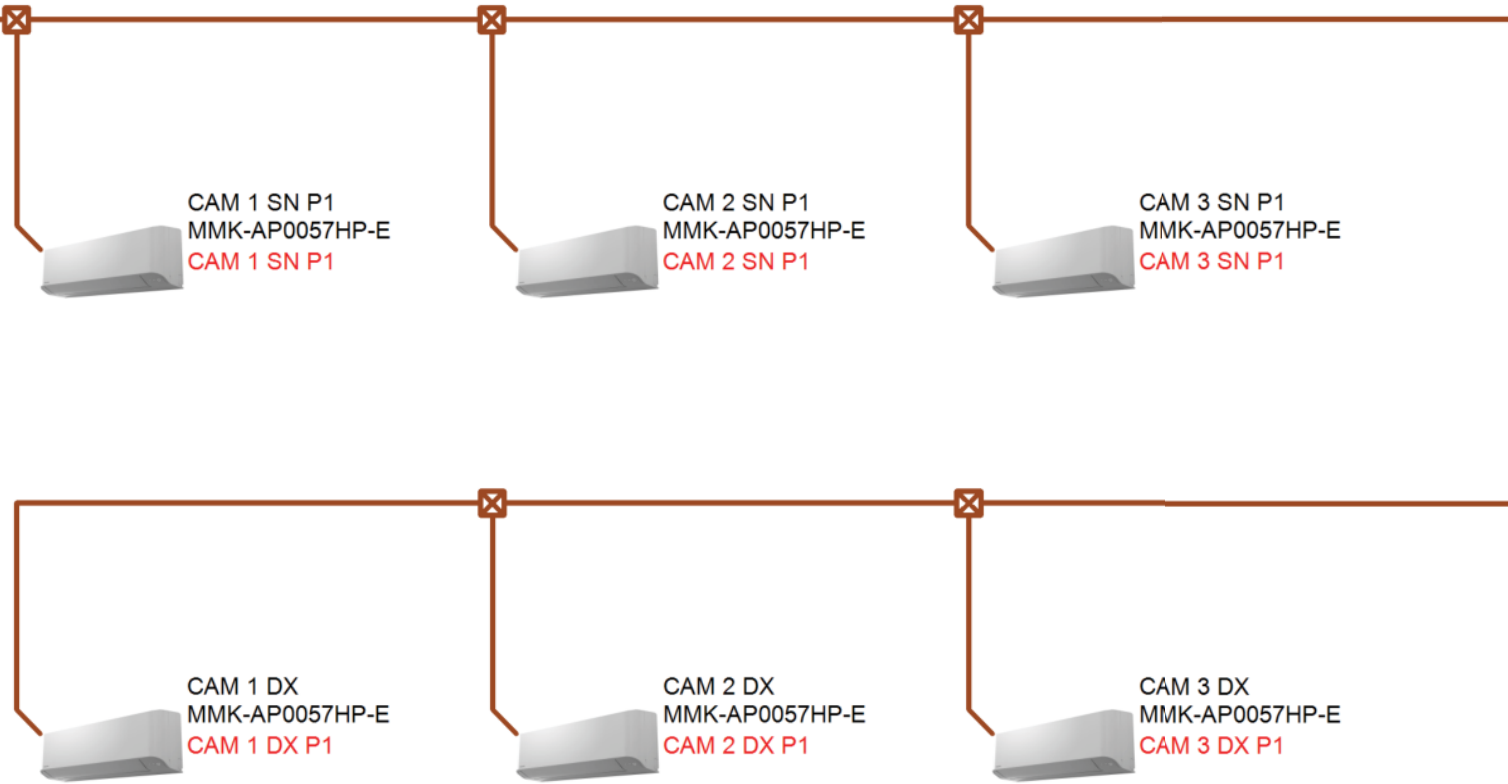

# SEER/SCOP

## Sistema 3

Model:	Sistema 3	System type	High Wall Compact
Model name	MMY-SAP1206HT8P-E	Season	Average
Outdoor heat exchanger:	-		
Indoor heat exchanger:	-	SEER(A)	6,32
type:	-		
compressor driver:	-	SCOP(A)	3,50

### COOLING

Item	Symbol	Value	Unit	Item	Symbol	Value	Unit
Rated cooling capacity	Prated,c	33,5	kW	Seasonal space cooling energy efficiency	$\eta_{s,c}$ (A)	198,6	%
					$\eta_{s,c}$ (C)	195,6	%
					$\eta_{s,c}$ (W)	201,4	%

Declared cooling capacity for part load at given outdoor temperatures  $T_j$  and indoor  $27^\circ/19^\circ\text{C}$  (dry/wet bulb)

$T_j = +35^\circ\text{C}$	Pdc	33,50	kW
$T_j = +30^\circ\text{C}$	Pdc	24,43	kW
$T_j = +25^\circ\text{C}$	Pdc	15,37	kW
$T_j = +20^\circ\text{C}$	Pdc	7,85	kW

Declared energy efficiency ratio or gas utilisation efficiency/auxiliary energy factor for part load at given outdoor

$T_j = +35^\circ\text{C}$	EERd	1,84	-
$T_j = +30^\circ\text{C}$	EERd	3,88	-
$T_j = +25^\circ\text{C}$	EERd	6,14	-
$T_j = +20^\circ\text{C}$	EERd	12,03	-

Degradation co-efficient for air conditioners(\*)

Cdc	-	-
-----	---	---

### HEATING

Item	Symbol	Value	Unit	Item	Symbol	Value	Unit
Rated heating capacity	Prated,c	37,5	kW	Seasonal space heating energy efficiency	$\eta_{s,h}$ (A)	137,0	%
					$\eta_{s,h}$ (C)	97,8	%
					$\eta_{s,h}$ (W)	236,4	%

Declared heating capacity for part load at given outdoor temperatures  $T_j$  and indoor  $27^\circ/19^\circ\text{C}$  (dry/wet bulb)

$T_j = -7^\circ\text{C}$	Pdh	22,00	kW
$T_j = +2^\circ\text{C}$	Pdh	13,03	kW
$T_j = +7^\circ\text{C}$	Pdh	8,80	kW
$T_j = +12^\circ\text{C}$	Pdh	5,67	kW
Tbiv = bivalent temperature	Pdh	22,00	kW
TOL = operation limit	Pdh	14,92	kW
$T_j = -15^\circ\text{C}$ (if TOL < -20 °C)	Pdh	21,10	kW
Bivalent temperature	Tbiv	-	°C

Declared energy efficiency ratio or gas utilisation efficiency/auxiliary energy factor for part load at given outdoor

$T_j = -7^\circ\text{C}$	COPd	2,01	-
$T_j = +2^\circ\text{C}$	COPd	3,22	-
$T_j = +7^\circ\text{C}$	COPd	5,62	-
$T_j = +12^\circ\text{C}$	COPd	7,13	-
Tbiv = bivalent temperature	COPd	2,01	-
TOL = operation limit	COPd	1,21	-
$T_j = -15^\circ\text{C}$ (if TOL < -20 °C)	COPd	1,57	-
Minimum operation temperature	Tol	-	°C

Degradation co-efficient for air conditioners(\*)

Cdc	-	-
-----	---	---

### Power consumption in modes other than "active mode"

Off mode	POFF	0,015	kW	Back-up heating capacity	PCK	0,115	kW
Thermostat-off mode	PTO	-	kW	Type of energy input	-	-	
Crankcase heater mode	PCK	0,115	kW	Standby mode	PSB	0,015	kW

### Other items

Capacity control	-						
Sound power level, indoor/outdoor measured	LWA	82	dB	For air-to-air air conditioner: air flow rate, outdoor measured	-	12200	m <sup>3</sup> /h
If engine driven: Emissions of nitrogen oxides	NOx	-	mg/kWh	For water/brine-to-air heat pumps: Rated brine or water flow rate, outdoor side	-	-	m <sup>3</sup> /h
GWP of the refrigerant	-		kg CO <sub>2</sub> eq (100 years)	heat exchanger			
Contact Details	-						

# Part Load Table

## MMY-SAP1206HT8P-E (12HP, 33,50kW system)

Cooling		Compressor + Outdoor Fan Power consumption (kW)																
Outdoor Unit (°C)		Outdoor Unit 100% Capacity (kW)	100%		90%		80%		70%		60%		50%		40%		30%	
			TC	PI	TC	PI	TC	PI	TC	PI	TC	PI	TC	PI	TC	PI	TC	PI
			(kW)	(kW)	(kW)	(kW)	(kW)	(kW)	(kW)	(kW)	(kW)	(kW)	(kW)	(kW)	(kW)	(kW)	(kW)	(kW)
40,0 °C	31,2	31,2	11,1	28,1	8,91	24,9	7,05	21,8	5,51	18,7	4,23	15,6	3,18	12,5	2,31	9,35	1,58	
39,0 °C	31,7	31,7	11,0	28,5	8,78	25,3	6,95	22,2	5,43	19,0	4,17	15,8	3,13	12,7	2,28	9,50	1,56	
37,0 °C	32,6	32,6	10,6	29,4	8,52	26,1	6,74	22,8	5,26	19,6	4,04	16,3	3,04	13,0	2,21	9,79	1,51	
35,0 °C	33,5	33,5	10,3	30,1	8,25	26,8	6,53	23,4	5,10	20,1	3,91	16,7	2,94	13,4	2,14	10,0	1,46	
33,0 °C	33,5	33,5	9,46	30,2	7,60	26,8	6,03	23,4	4,73	20,1	3,64	16,8	2,75	13,4	2,00	10,0	1,37	
31,0 °C	33,5	33,5	8,73	30,2	7,03	26,8	5,60	23,4	4,40	20,1	3,40	16,8	2,57	13,4	1,88	10,0	1,29	
30,0 °C	33,5	33,5	8,40	30,2	6,77	26,8	5,39	23,4	4,24	20,1	3,28	16,8	2,49	13,4	1,82	10,0	1,25	
29,0 °C	33,5	33,5	8,09	30,2	6,52	26,8	5,20	23,4	4,10	20,1	3,18	16,8	2,41	13,4	1,76	10,0	1,22	
27,0 °C	33,5	33,5	7,51	30,2	6,07	26,8	4,85	23,4	3,83	20,1	2,97	16,8	2,26	13,4	1,66	10,0	1,14	
25,0 °C	33,5	33,5	6,99	30,2	5,66	26,8	4,53	23,4	3,58	20,1	2,79	16,8	2,12	13,4	1,56	10,0	1,08	
23,0 °C	33,5	33,5	6,65	30,2	5,40	26,8	4,33	23,4	3,43	20,1	2,67	16,8	2,04	13,4	1,50	10,0	1,04	
21,0 °C	33,5	33,5	6,49	30,2	5,27	26,8	4,24	23,4	3,36	20,1	2,63	16,8	2,00	13,4	1,48	10,0	1,02	
20,0 °C	33,5	33,5	6,42	30,2	5,22	26,8	4,20	23,4	3,33	20,1	2,60	16,8	1,99	13,4	1,47	10,0	1,02	
19,0 °C	33,5	33,5	6,36	30,2	5,17	26,8	4,16	23,4	3,30	20,1	2,58	16,8	1,98	13,4	1,46	10,0	1,01	
17,0 °C	33,5	33,5	6,24	30,2	5,08	26,8	4,09	23,4	3,25	20,1	2,55	16,8	1,95	13,4	1,44	10,0	1,00	
15,0 °C	33,5	33,5	6,14	30,2	5,00	26,8	4,03	23,4	3,21	20,1	2,52	16,8	1,93	13,4	1,42	10,0	0,99	





TC : Total Capacity      PI : Power Input  
Indoor air temperature conditions : 27,0°C dry-bulb / 19,0°C wet bulb

Heating			Compressor + Outdoor Fan Power consumption (kW)															
Outdoor Unit Dry-Bulb (°C)    Wet-Bulb (°C)		Outdoor Unit 100% Heating Capacity (kW)	100%		90%		80%		70%		60%		50%		40%		30%	
			Capacity		Capacity		Capacity		Capacity		Capacity		Capacity		Capacity		Capacity	
			TC	PI	TC	PI	TC	PI	TC	PI	TC	PI	TC	PI	TC	PI	TC	PI
(kW)	(kW)	(kW)	(kW)	(kW)	(kW)	(kW)	(kW)	(kW)	(kW)	(kW)	(kW)	(kW)	(kW)	(kW)	(kW)	(kW)	(kW)	(kW)
15,0	13,7	37,5	37,5	8,00	33,8	6,70	30,0	5,60	26,2	4,66	22,5	3,85	18,8	3,12	15,0	2,42	11,2	1,72
13,0	11,8	37,5	37,5	8,37	33,8	6,97	30,0	5,80	26,2	4,81	22,5	3,96	18,8	3,20	15,0	2,49	11,2	1,77
11,0	9,80	37,5	37,5	8,80	33,8	7,29	30,0	6,03	26,2	4,98	22,5	4,09	18,8	3,30	15,0	2,56	11,2	1,83
9,00	7,90	37,5	37,5	9,25	33,8	7,63	30,0	6,28	26,2	5,16	22,5	4,22	18,8	3,39	15,0	2,64	11,2	1,89
7,00	6,00	37,5	37,5	9,76	33,8	8,00	30,0	6,55	26,2	5,36	22,5	4,36	18,8	3,50	15,0	2,71	11,2	1,95
5,00	4,10	36,2	36,2	9,68	32,5	7,94	28,9	6,50	25,3	5,32	21,7	4,33	18,1	3,47	14,5	2,69	10,8	1,94
3,00	2,20	34,8	34,8	9,61	31,3	7,88	27,9	6,45	24,4	5,28	20,9	4,30	17,4	3,45	13,9	2,67	10,4	1,92
0,00	-0,70	32,8	32,8	9,50	29,5	7,79	26,2	6,38	22,9	5,22	19,7	4,24	16,4	3,41	13,1	2,64	9,83	1,90
-3,00	-3,70	30,6	30,6	9,38	27,6	7,69	24,5	6,30	21,5	5,15	18,4	4,19	15,3	3,36	12,3	2,61	9,19	1,87
-5,00	-5,60	29,3	29,3	9,31	26,4	7,63	23,4	6,25	20,5	5,11	17,6	4,16	14,7	3,34	11,7	2,59	8,79	1,86
-7,00	-7,60	27,9	27,9	9,23	25,1	7,57	22,3	6,20	19,5	5,07	16,7	4,12	13,9	3,31	11,2	2,57	8,37	1,84
-10,0	-10,5	25,8	25,8	9,12	23,3	7,47	20,7	6,12	18,1	5,01	15,5	4,07	12,9	3,27	10,3	2,54	7,75	1,82
-14,5	-15,0	22,7	22,7	8,94	20,4	7,33	18,1	6,00	15,9	4,91	13,6	4,00	11,3	3,21	9,06	2,49	6,80	1,79

TC : Total Capacity      PI : Power Input  
Indoor air temperature conditions : 20,0°C dry-bulb

# Project Wiring Diagram

Control Wiring Legend	Label	Wiring	Wiring Size and Length
Outdoor - Indoor Control Wiring	Uv(U1,U2)	2 core, no polarity, shielded	1,25mm <sup>2</sup> up to 1000m & 2,0mm <sup>2</sup> up to 2000m
Central Control Wiring	Uh(U3,U4)	2 core, no polarity, shielded	1,25mm <sup>2</sup> up to 1000m & 2,0mm <sup>2</sup> up to 2000m
Outdoor Units Control Wiring	Uc(U5,U6)	2 core, no polarity, shielded	1,25mm <sup>2</sup> to 2,0mm <sup>2</sup> up to 100m
Remote Controller Wiring	A,B	2 core, no polarity, shielded	0,5mm <sup>2</sup> to 2,0mm <sup>2</sup> up to 500m (Wireless Remote Controller up to 400m). Group Control wiring is up to 200m

Symbol Legend	
	Multi Flow Selector
	Flow Selector
	PMV kit
	Electrical isolator

Note: Power Wiring should comply with Local, National and International Regulation.

## Sistema 1

Floor: TERRAZ Elevation: 0,00m

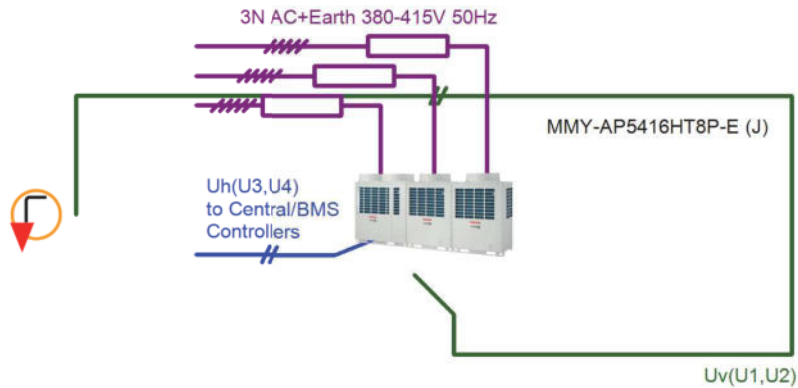

# Project Wiring Diagram

Control Wiring Legend	Label	Wiring	Wiring Size and Length
Outdoor - Indoor Control Wiring	Uv(U1,U2)	2 core, no polarity, shielded	1,25mm <sup>2</sup> up to 1000m & 2,0mm <sup>2</sup> up to 2000m
Central Control Wiring	Uh(U3,U4)	2 core, no polarity, shielded	1,25mm <sup>2</sup> up to 1000m & 2,0mm <sup>2</sup> up to 2000m
Outdoor Units Control Wiring	Uc(U5,U6)	2 core, no polarity, shielded	1,25mm <sup>2</sup> to 2,0mm <sup>2</sup> up to 100m
Remote Controller Wiring	A,B	2 core, no polarity, shielded	0,5mm <sup>2</sup> to 2,0mm <sup>2</sup> up to 500m (Wireless Remote Controller up to 400m). Group Control wiring is up to 200m

Symbol Legend	
	Multi Flow Selector
	Flow Selector
	PMV kit
	Electrical isolator

Note: Power Wiring should comply with Local, National and International Regulation.

## Sistema 1

Floor: SALA RI Elevation: Above Outdoor Unit -15,00m

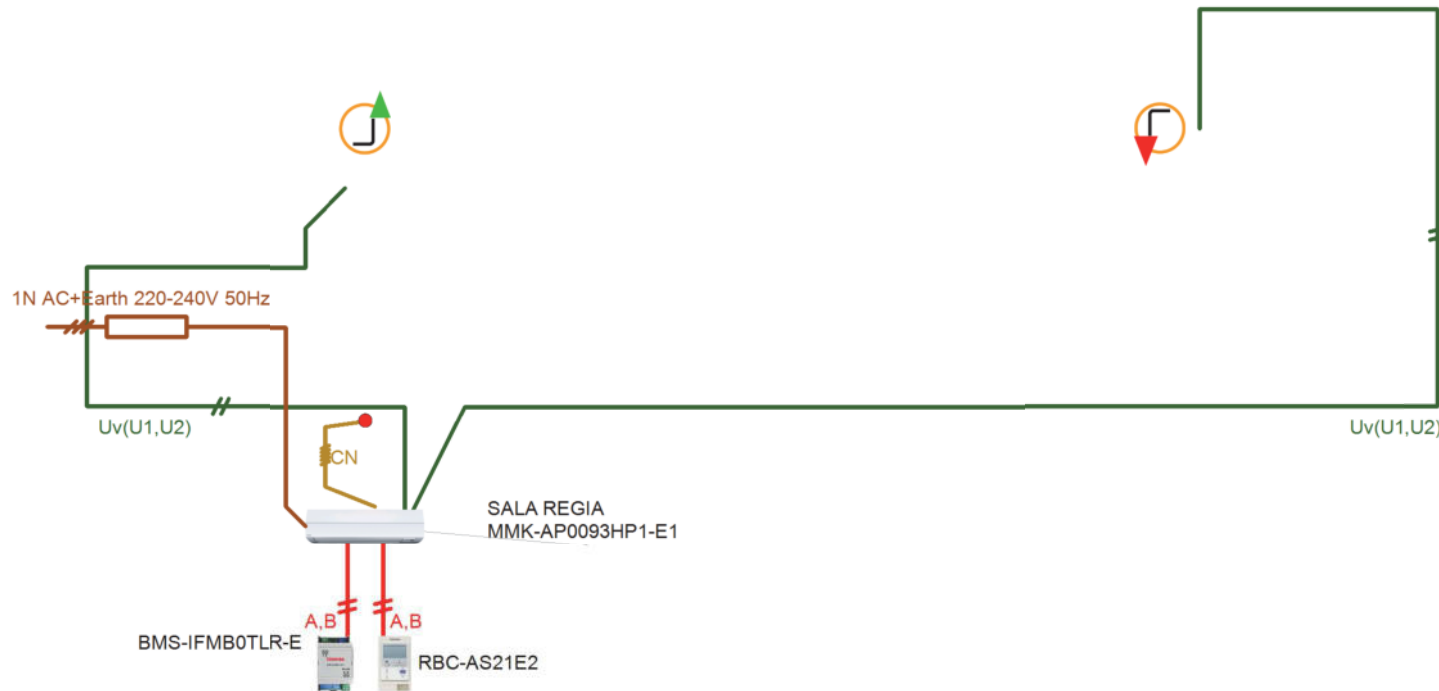

# Project Wiring Diagram

Control Wiring Legend	Label	Wiring	Wiring Size and Length
Outdoor - Indoor Control Wiring	Uv(U1,U2)	2 core, no polarity, shielded	1,25mm <sup>2</sup> up to 1000m & 2,0mm <sup>2</sup> up to 2000m
Central Control Wiring	Uh(U3,U4)	2 core, no polarity, shielded	1,25mm <sup>2</sup> up to 1000m & 2,0mm <sup>2</sup> up to 2000m
Outdoor Units Control Wiring	Uc(U5,U6)	2 core, no polarity, shielded	1,25mm <sup>2</sup> to 2,0mm <sup>2</sup> up to 100m
Remote Controller Wiring	A,B	2 core, no polarity, shielded	0,5mm <sup>2</sup> to 2,0mm <sup>2</sup> up to 500m (Wireless Remote Controller up to 400m). Group Control wiring is up to 200m

Symbol Legend	
	Multi Flow Selector
	Flow Selector
	PMV kit
	Electrical isolator

Note: Power Wiring should comply with Local, National and International Regulation.

## Sistema 1

Floor: SALA T1 Elevation: Above Outdoor Unit -20.00m

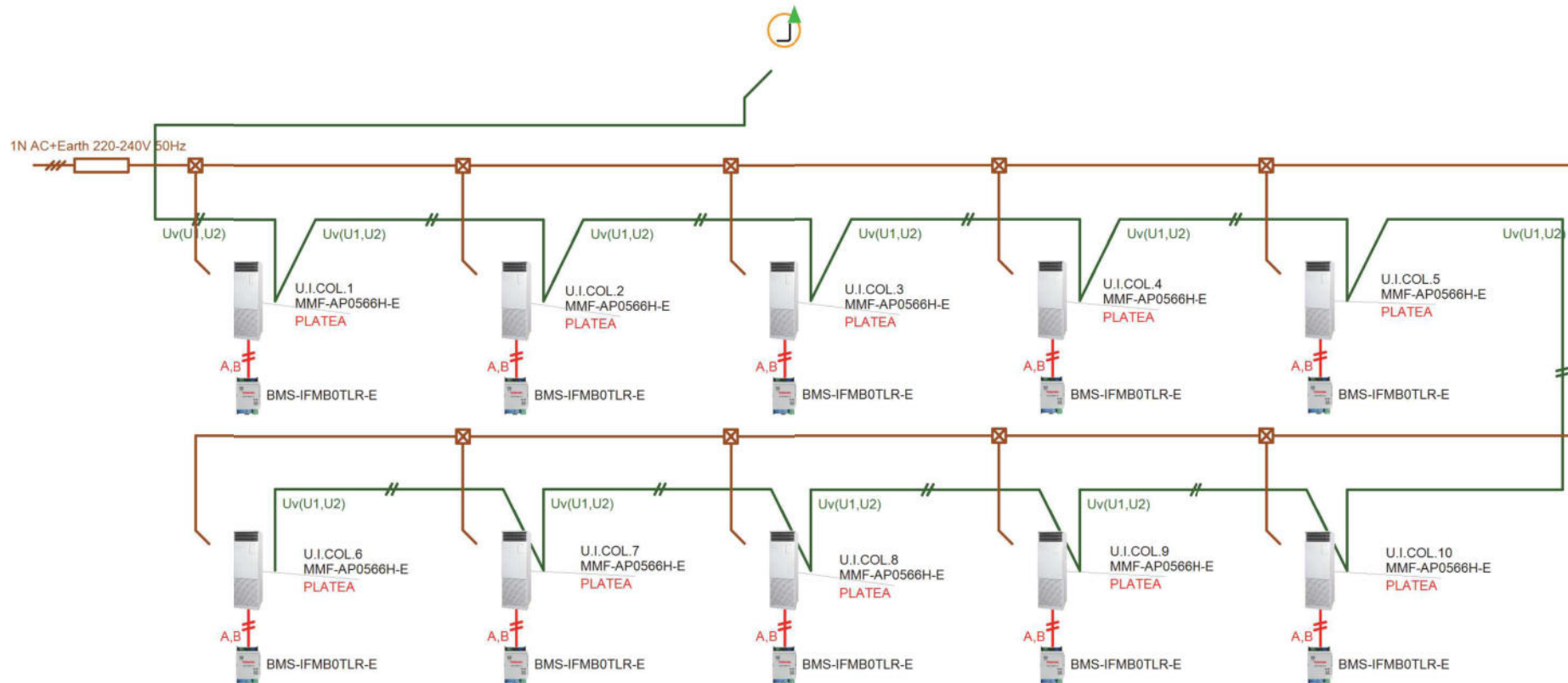

# Project Wiring Diagram

Control Wiring Legend	Label	Wiring	Wiring Size and Length
Outdoor - Indoor Control Wiring	Uv(U1,U2)	2 core, no polarity, shielded	1,25mm <sup>2</sup> up to 1000m & 2,0mm <sup>2</sup> up to 2000m
Central Control Wiring	Uh(U3,U4)	2 core, no polarity, shielded	1,25mm <sup>2</sup> up to 1000m & 2,0mm <sup>2</sup> up to 2000m
Outdoor Units Control Wiring	Uc(U5,U6)	2 core, no polarity, shielded	1,25mm <sup>2</sup> to 2,0mm <sup>2</sup> up to 100m
Remote Controller Wiring	A,B	2 core, no polarity, shielded	0,5mm <sup>2</sup> to 2,0mm <sup>2</sup> up to 500m (Wireless Remote Controller up to 400m). Group Control wiring is up to 200m

Symbol Legend	
	Multi Flow Selector
	Flow Selector
	PMV kit
	Electrical isolator

Note: Power Wiring should comply with Local, National and International Regulation.

## Sistema 2



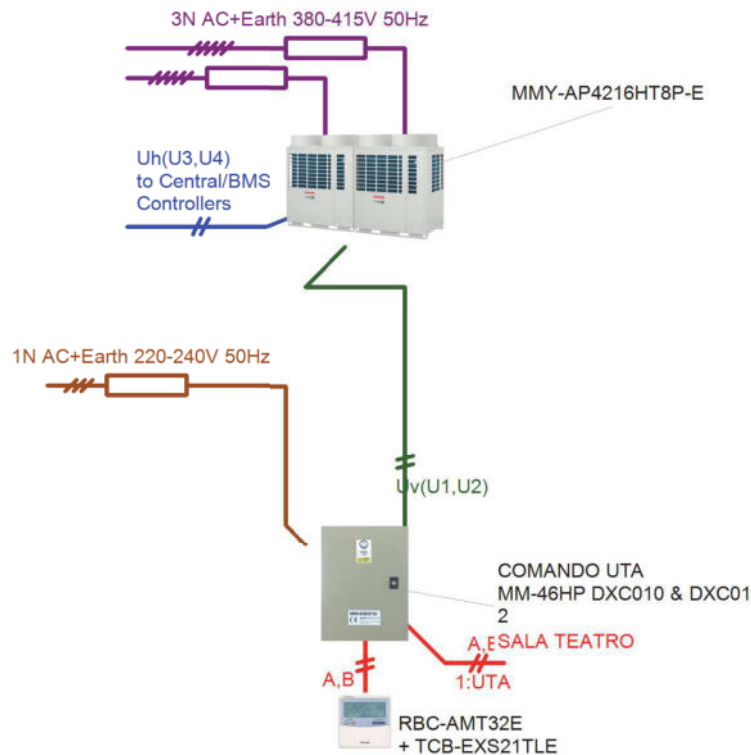

Floor: PIANO 1 Elevation: 0,00m





# Project Wiring Diagram

Control Wiring Legend	Label	Wiring	Wiring Size and Length
Outdoor - Indoor Control Wiring	U1,U2	2 core, no polarity, shielded	1,25mm <sup>2</sup> up to 1000m & 2,0mm <sup>2</sup> up to 2000m
Central Control Wiring	U3,U4	2 core, no polarity, shielded	1,25mm <sup>2</sup> up to 1000m & 2,0mm <sup>2</sup> up to 2000m
Outdoor Units Control Wiring	U5,U6	2 core, no polarity, shielded	1,25mm <sup>2</sup> to 2,0mm <sup>2</sup> up to 100m
Remote Controller Wiring	A,B	2 core, no polarity, shielded	0,5mm <sup>2</sup> to 2,0mm <sup>2</sup> up to 500m (Wireless Remote Controller up to 400m). Group Control wiring is up to 200m

Symbol Legend	
	Multi Flow Selector
	Flow Selector
	PMV kit
	Electrical isolator

Note: Power Wiring should comply with Local, National and International Regulation.

## Sistema 3

Floor: PIANO 1 Elevation: 0,00m

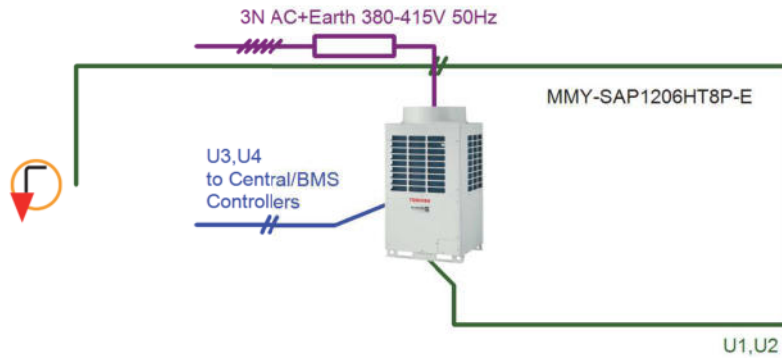

# Project Wiring Diagram

Control Wiring Legend	Label	Wiring	Wiring Size and Length
Outdoor - Indoor Control Wiring	U1,U2	2 core, no polarity, shielded	1,25mm <sup>2</sup> up to 1000m & 2,0mm <sup>2</sup> up to 2000m
Central Control Wiring	U3,U4	2 core, no polarity, shielded	1,25mm <sup>2</sup> up to 1000m & 2,0mm <sup>2</sup> up to 2000m
Outdoor Units Control Wiring	U5,U6	2 core, no polarity, shielded	1,25mm <sup>2</sup> to 2,0mm <sup>2</sup> up to 100m
Remote Controller Wiring	A,B	2 core, no polarity, shielded	0,5mm <sup>2</sup> to 2,0mm <sup>2</sup> up to 500m (Wireless Remote Controller up to 400m). Group Control wiring is up to 200m

Symbol Legend	
	Multi Flow Selector
	Flow Selector
	PMV kit
	Electrical isolator

Note: Power Wiring should comply with Local, National and International Regulation.

## Sistema 3

Floor: PIANO 3 Elevation: Above Outdoor Unit -5,00m

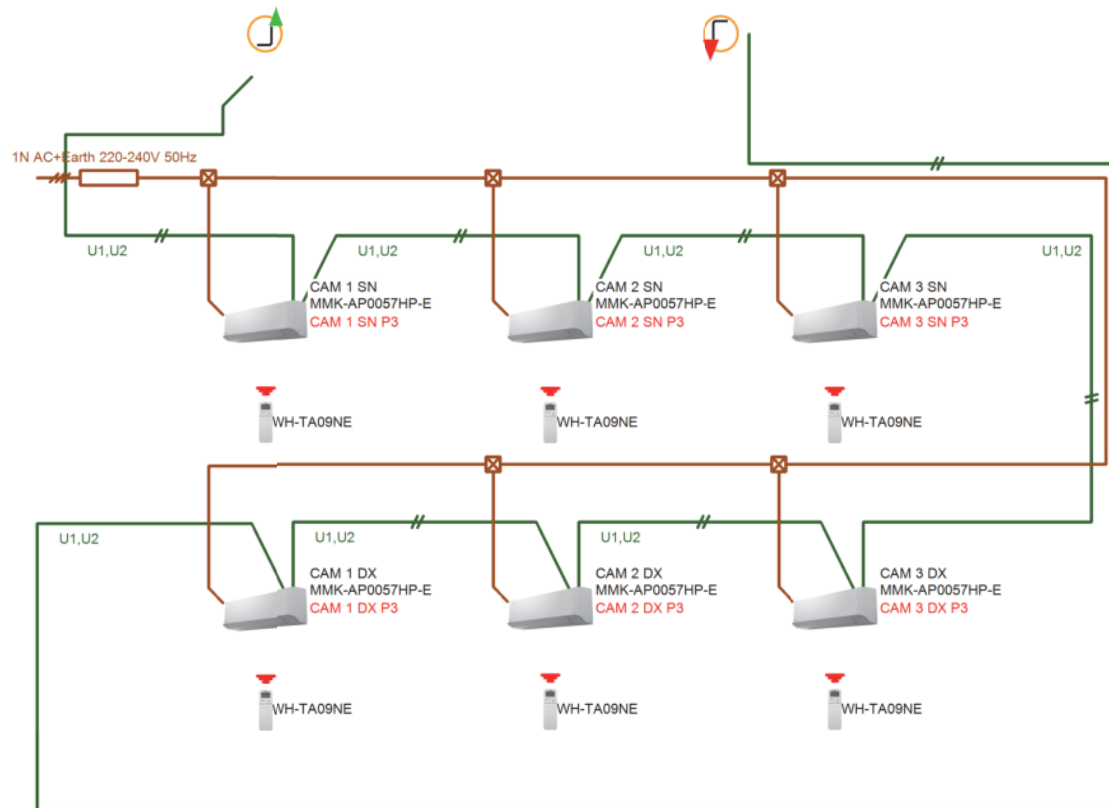

# Project Wiring Diagram

Control Wiring Legend	Label	Wiring	Wiring Size and Length
Outdoor - Indoor Control Wiring	U1,U2	2 core, no polarity, shielded	1,25mm <sup>2</sup> up to 1000m & 2,0mm <sup>2</sup> up to 2000m
Central Control Wiring	U3,U4	2 core, no polarity, shielded	1,25mm <sup>2</sup> up to 1000m & 2,0mm <sup>2</sup> up to 2000m
Outdoor Units Control Wiring	U5,U6	2 core, no polarity, shielded	1,25mm <sup>2</sup> to 2,0mm <sup>2</sup> up to 100m
Remote Controller Wiring	A,B	2 core, no polarity, shielded	0,5mm <sup>2</sup> to 2,0mm <sup>2</sup> up to 500m (Wireless Remote Controller up to 400m). Group Control wiring is up to 200m

Symbol Legend	
	Multi Flow Selector
	Flow Selector
	PMV kit
	Electrical isolator

Note: Power Wiring should comply with Local, National and International Regulation.

## Sistema 3

Floor: PIANO 2 Elevation: Above Outdoor Unit -7,50m

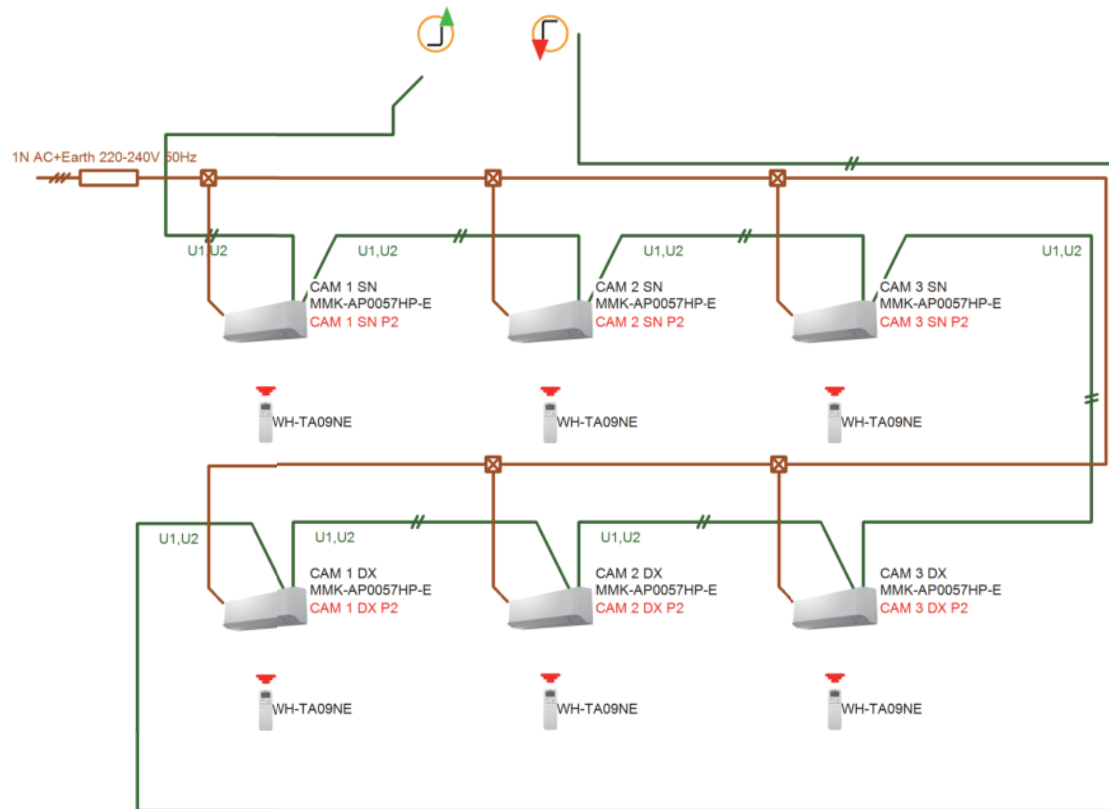

# Project Wiring Diagram

Control Wiring Legend	Label	Wiring	Wiring Size and Length
Outdoor - Indoor Control Wiring	U1,U2	2 core, no polarity, shielded	1,25mm <sup>2</sup> up to 1000m & 2,0mm <sup>2</sup> up to 2000m
Central Control Wiring	U3,U4	2 core, no polarity, shielded	1,25mm <sup>2</sup> up to 1000m & 2,0mm <sup>2</sup> up to 2000m
Outdoor Units Control Wiring	U5,U6	2 core, no polarity, shielded	1,25mm <sup>2</sup> to 2,0mm <sup>2</sup> up to 100m
Remote Controller Wiring	A,B	2 core, no polarity, shielded	0,5mm <sup>2</sup> to 2,0mm <sup>2</sup> up to 500m (Wireless Remote Controller up to 400m). Group Control wiring is up to 200m

Symbol Legend	
	Multi Flow Selector
	Flow Selector
	PMV kit
	Electrical isolator

Note: Power Wiring should comply with Local, National and International Regulation.

## Sistema 3

Floor: PIANO 1 Elevation: Above Outdoor Unit -11,00m

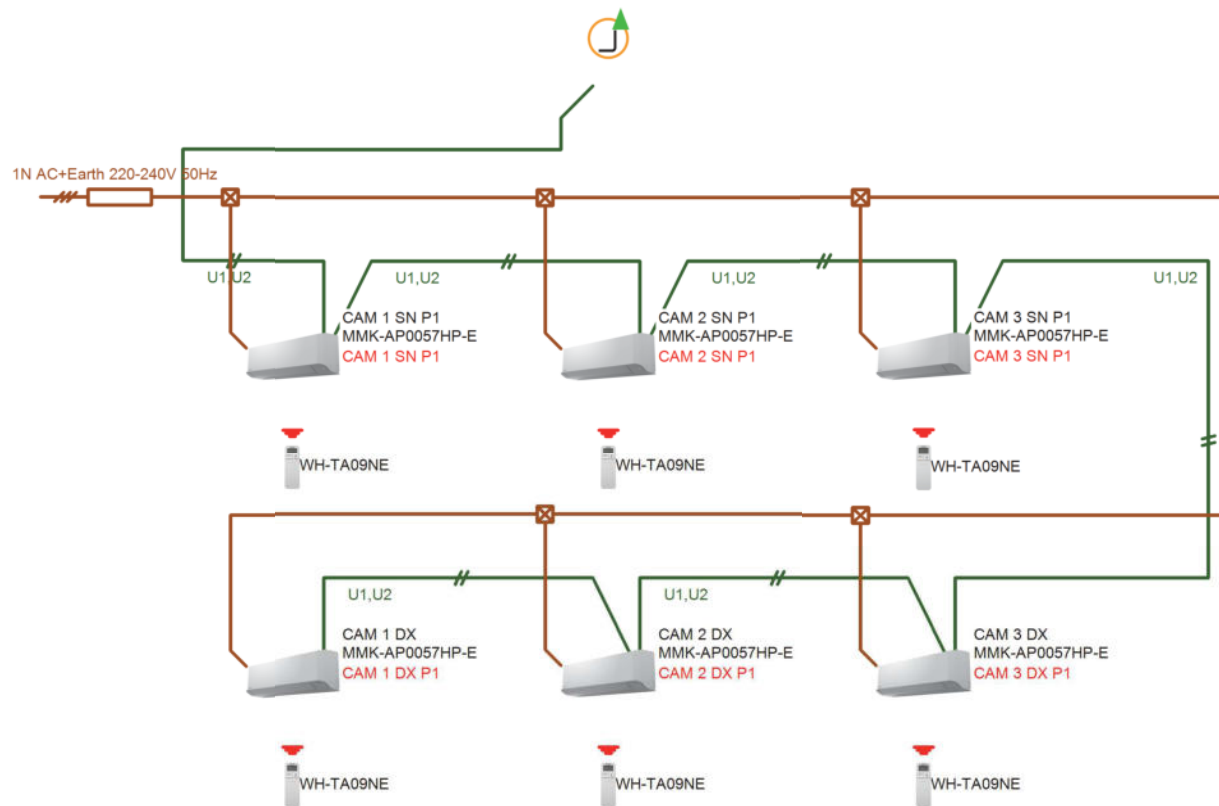

# Piping Diagram

## Sistema 1

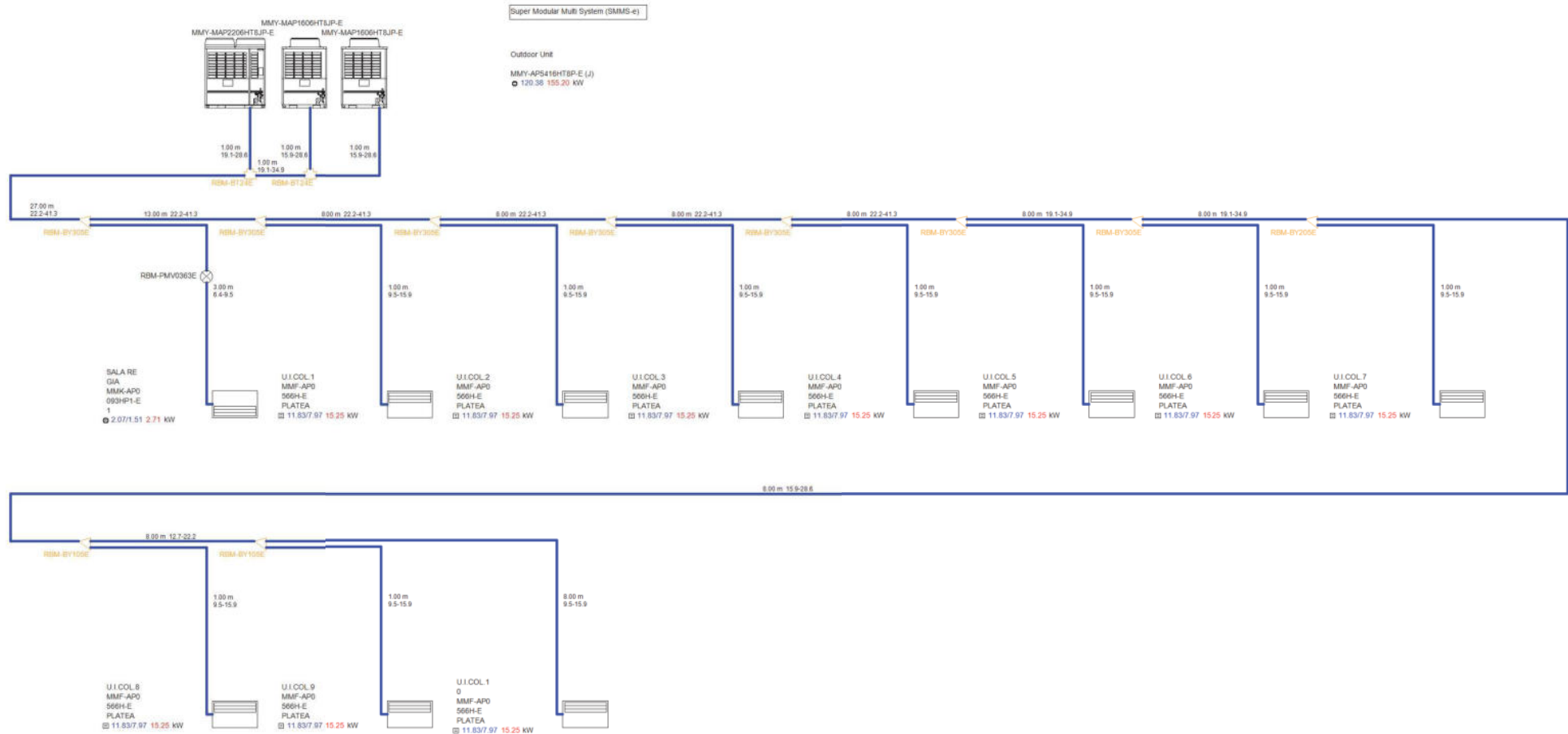





# Piping Diagram

## Sistema 2

Super Modular Multi System (SMMS-e)

Outdoor Unit

MMY-AP4216HT8P-E  
⊖ 120.24 130.43 kW

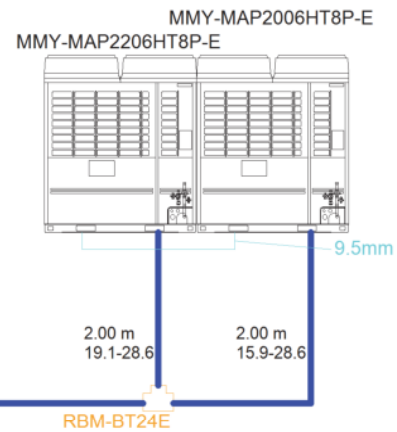

COMAND  
O UTA  
MM-46HP  
DXC010 &  
DXC012  
SALA TEATR  
O  
⊖ 120.24/0.00 130.43 kW



## Sistema 2

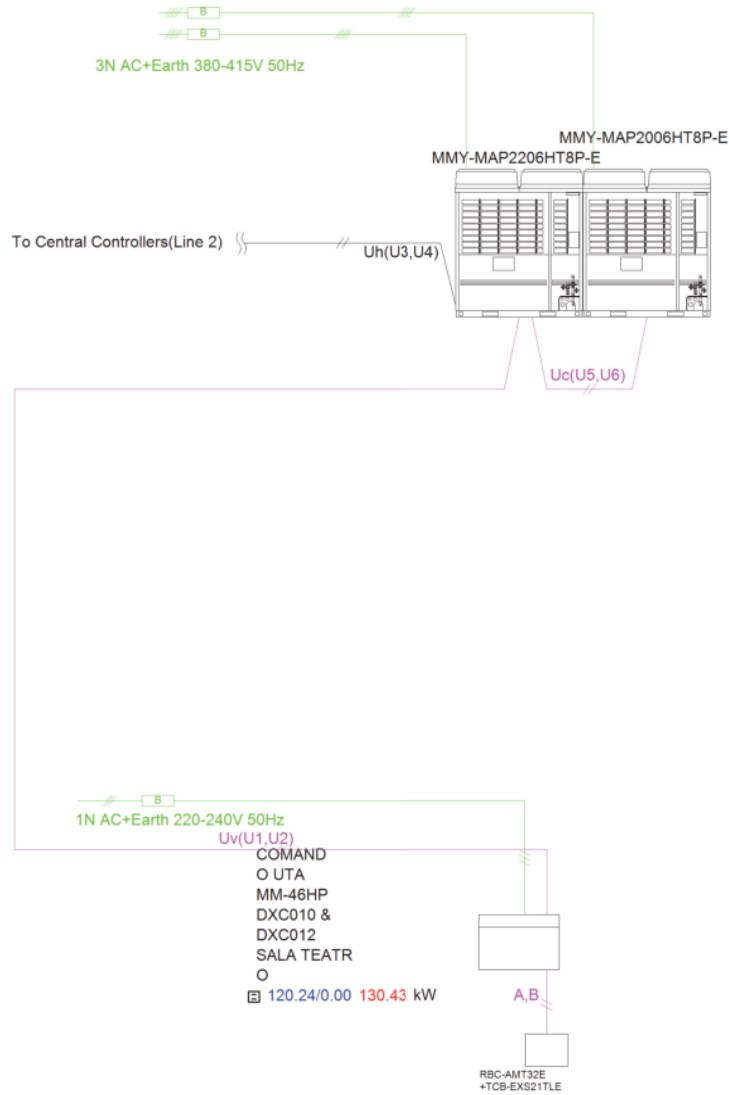

Super Modular Multi System (SMMS-e)

Outdoor Unit

MMY-AP4216HT8P-E  
 © 120.24 130.43 kW

Uc(U5,U6):Control wiring between Outdoor Units(2 Core Shield Wire)

Uh(U3,U4):Central control Wiring(2 Core Shield Wire)

Uv(U1,U2):Control for Outdoor Unit-Indoor Unit(2 Core Shield Wire)

A,B Wiring:For Remote controller wiring(2 Core)

## Sistema 2

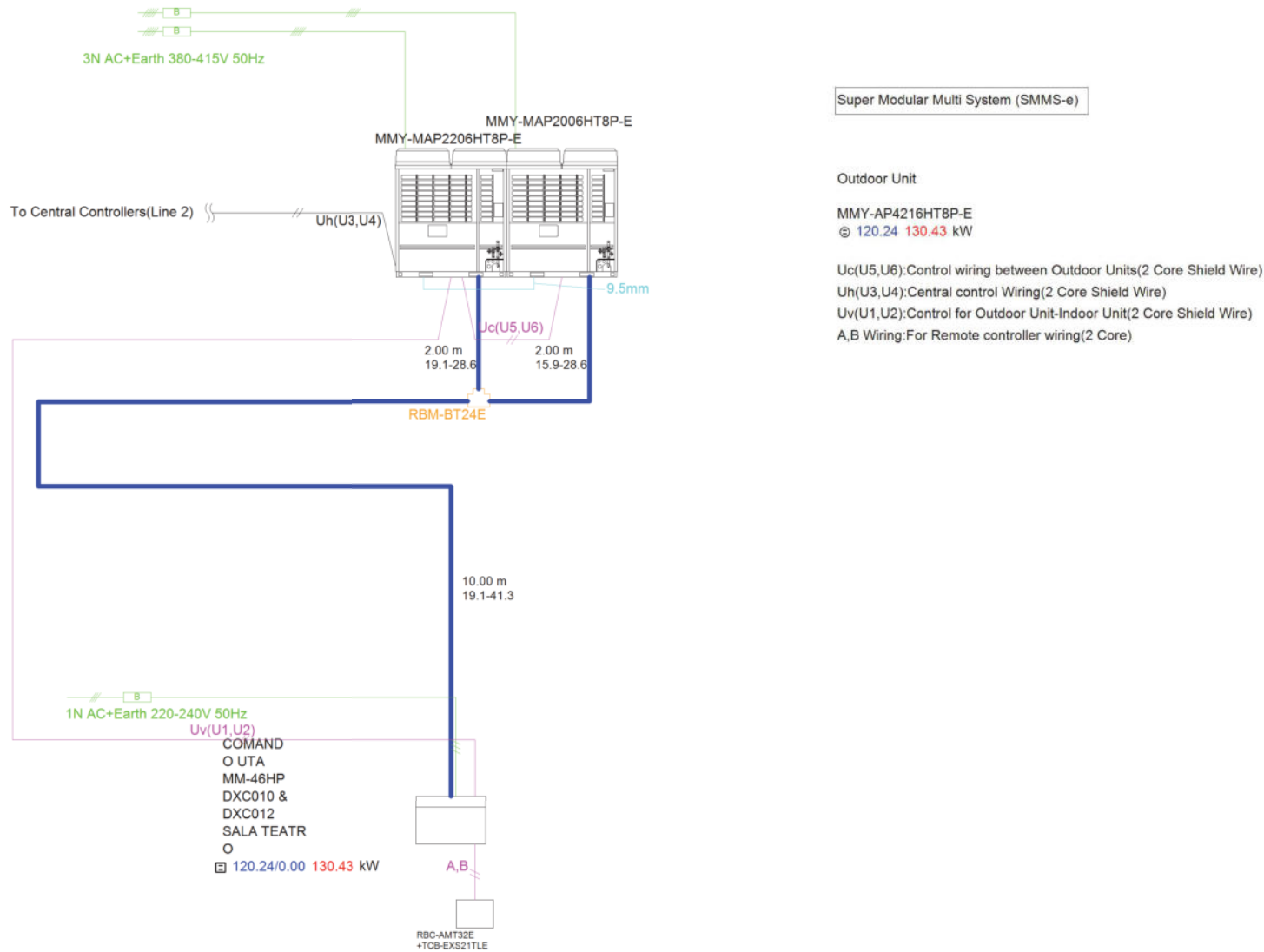

# Piping Diagram

## Sistema 3

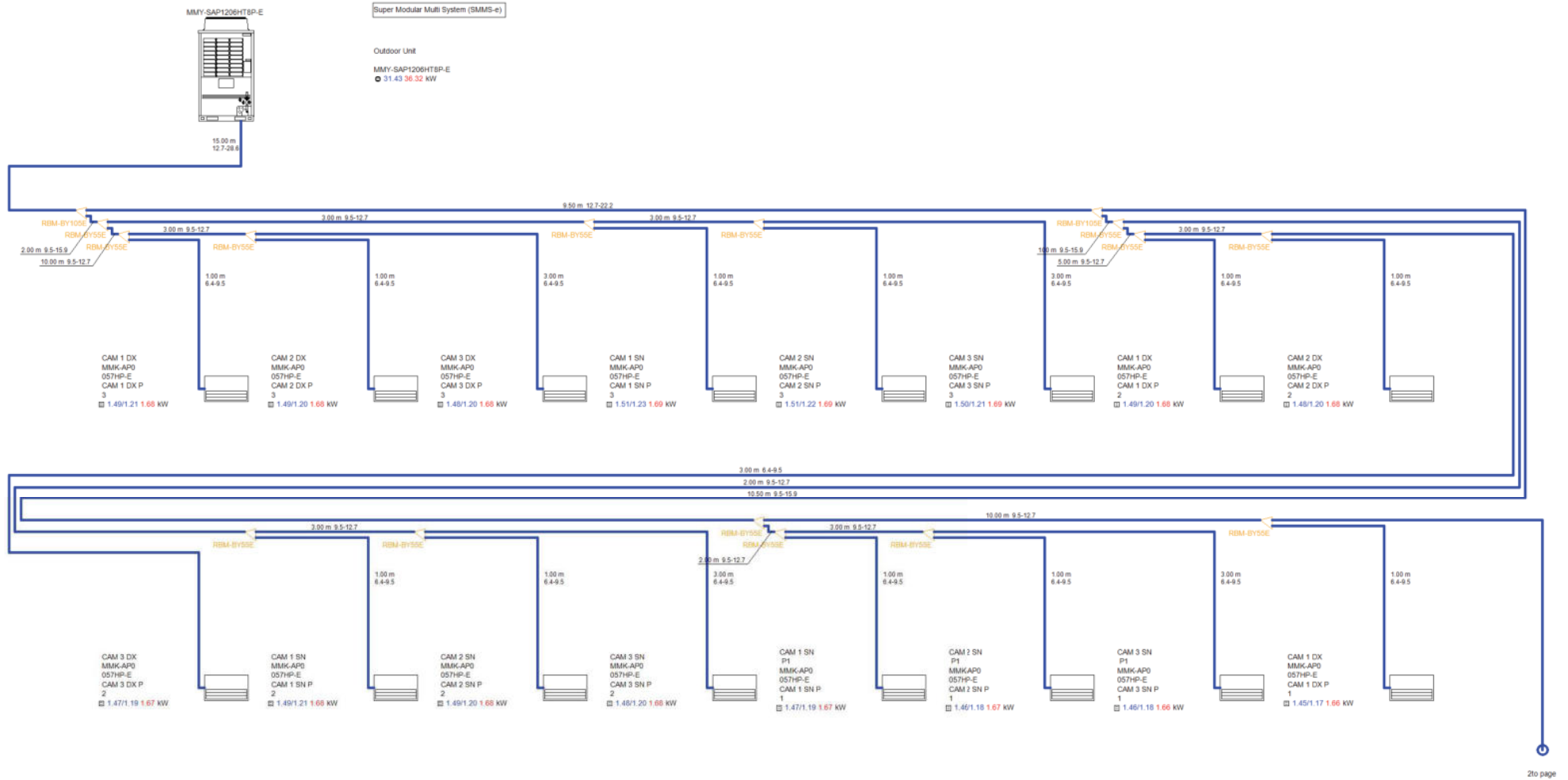

## Sistema 3

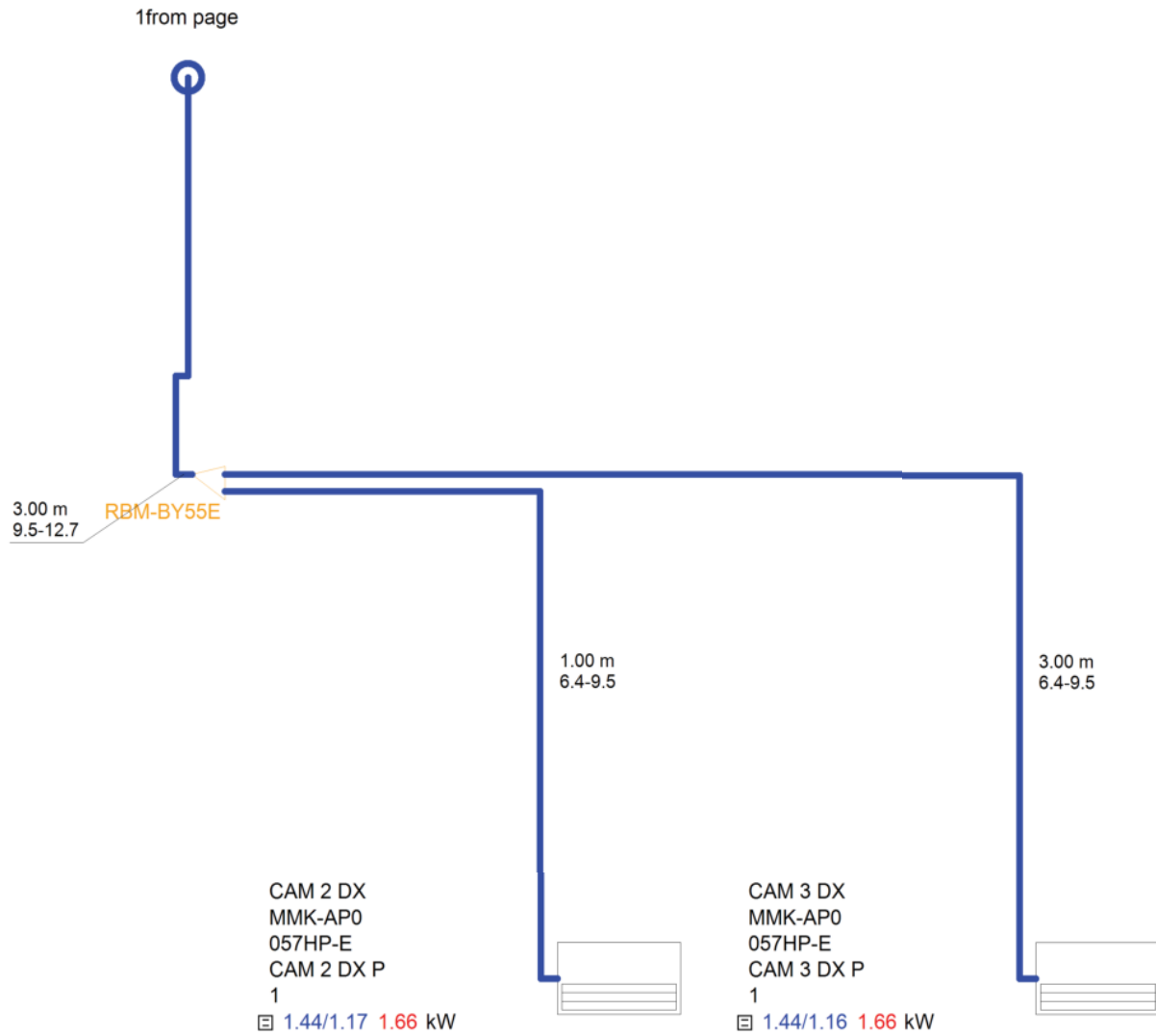

# Wiring Diagram

## Sistema 3

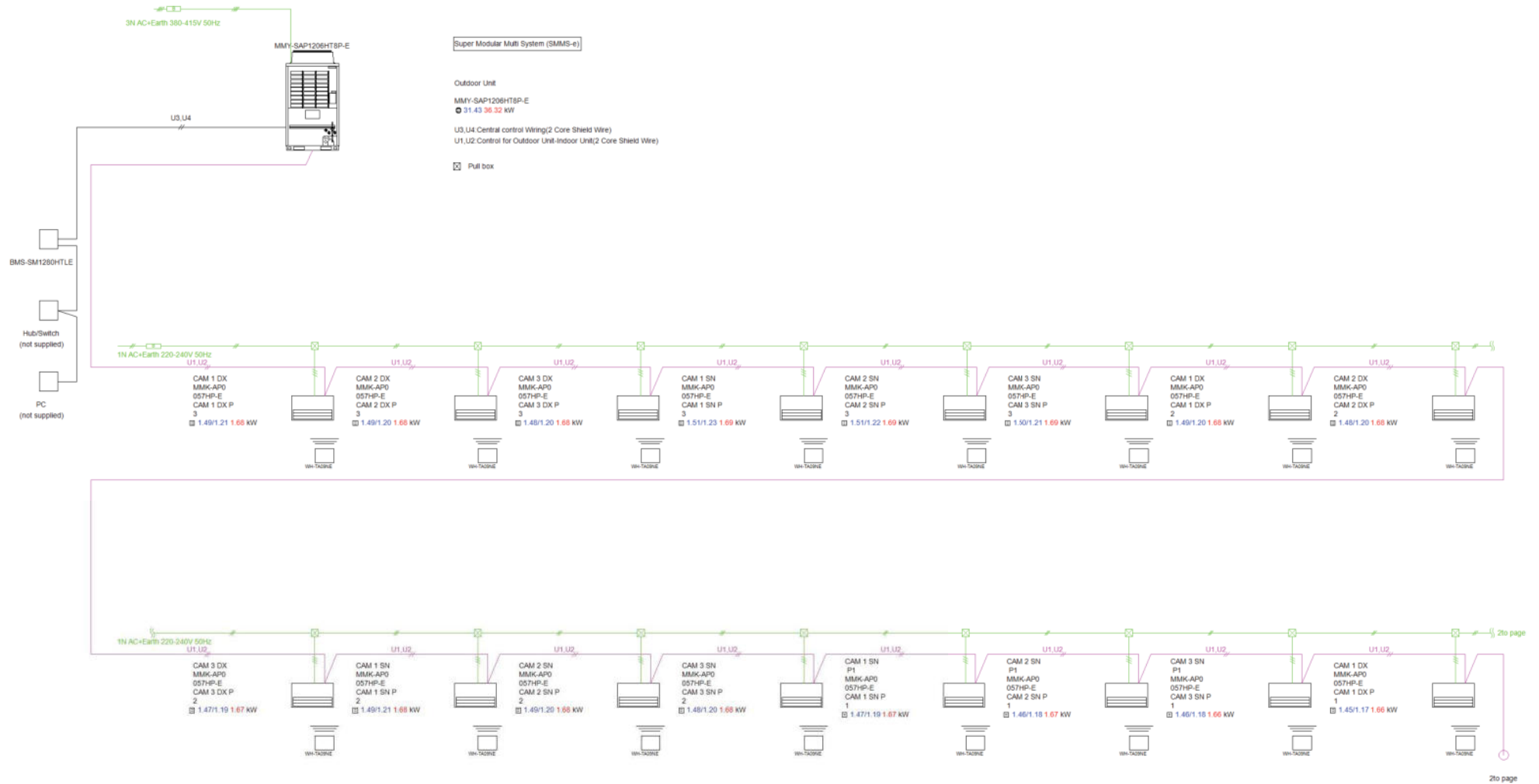

## Sistema 3

1from page

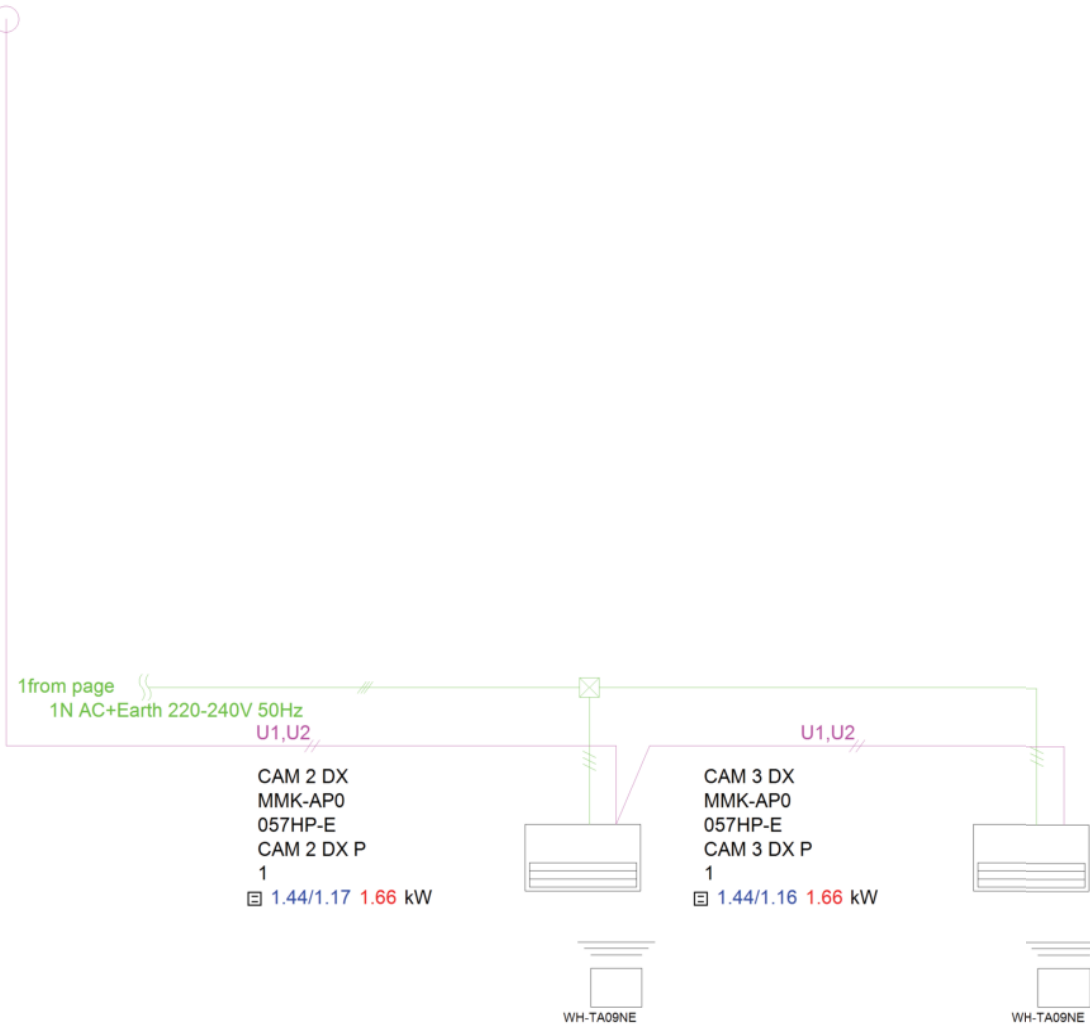

## Sistema 3

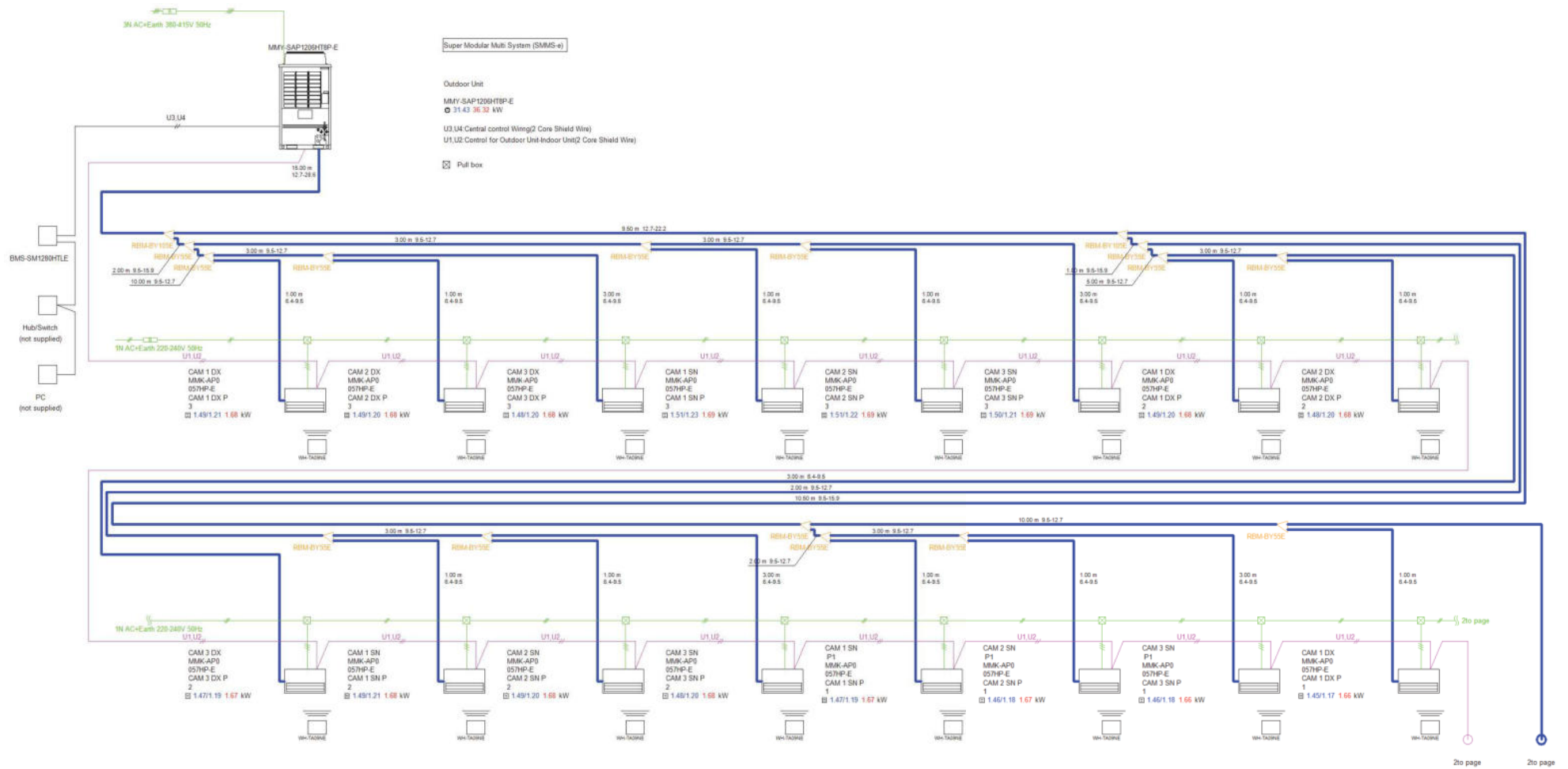

## Sistema 3

